



















































































































MODECO
EXPERT

CATALOGUE 2024/25

HAND TOOLS, POWER TOOLS
AND ACCESSORIES



PICTOGRAMS

 Magnetic tip	 Satin surface finish	 M36 M36 staple	 Additional blades	 S2 steel	 Plastic
 Tip hardness 48-52 HRC	 1/2" drive	 M300 M300 nail type	 Quick blade replacement	 Concrete	 Key less mount
 Insulated blade 1000 V	 Satin surface finish	 Sharpened tip	 3 step blade extending facility 1..2..3	 Brick	 Minimum thickness of riveted material min. 3 mm
 Pliers jaws hardness ~56 HRC	 Chrome Vanadium Steel	 Zinc coating	 Number of blades included 10x	 Aluminum	 Additional blades
 Maximum spacing Ø 35	 Reversible ratchet handle	 1000pcs in a box	 Safety lock	 Wood	 Quick blade replacement
 Pliers working range max Ø 0,5-60	 Torx key tip	 M53 staple	 Quick replacement facility	 Steel	 Non slip handle
 VDE-certified	 Hardness of wrench jaws 44-48 HRC	 Made in Poland	 Plastic handle	 Plasterboard	 Cable cutter
 Insulated handles 1000 V	 Satin surface finish	 Lifetime guarantee 100 YEARS	 3 cutting edges	 Gres Tiles	 Made of chromium-molybdenum steel
 External circlip pliers	 Ball end shaft for working at angles 25°	 ABS plugs	 Fine tooth saw tip easy start	 Stal nierdzewna Stainless steel	 18 V LI-ION battery
 Internal circlip pliers	 Cleans	 Reinforced construction	 Special tooth covering	 Paving sett	 Waterproof material
 Hardness of wrench jaws 55 HRC	 Lubricates, ex. padlocks	 Wall thickness	 Hole cutting	 Stone	 Rubber base
 Magnetic tip	 Lubricates, ex. camshaft chains	 Pressure force	 Screw secured blade	 Zinc/Copper	 Max. revolutions speed max 12000 rpm
 Special hexagonal shape MAXXORIVE	 Lubricates, ex. transfer boxes	 Stainless steel	 Two cutting edges	 Arm strap	 Doesn't require water cooling
 x72 72 tooth ratchet mechanism	 Cleans lacquered surfaces	 Wooden handle	 Carbide HM	 Reduction ring	 Hexagonal grip
 Satin surface finish	 Cleans and lubricates, ex. bicycle parts	 Underlay thickness h	 Special impact cap for hammer tapping	 Upwards mixing effect	 Max. diam. of the diamond hole saw Ø max 75 mm
 Specially profiled offset for obscured spaces	 Lubricates, ex. pistons	 Leakage current approved 1,0 kV	 Tear resistant material 600 D POLYESTER	 Downwards mixing effect	 Stainless steel
 70° offset	 Lubricates, ex. discs	 Blade width 18 mm	 Rubber coated handle	 Homogenous mixing effect	 1/4" hexagonal chuck HEX 1/4"
 Satin surface finish	 PVC folding ruler	 Blade breaker BREAKER	 ACR system ACR	 Chemical specification Sn60 Pb40	 Wire thickness 0,35mm BRASS
 1/2" drive	 M11 staple	 Additional blades x6 GRATIS	 Bit hardness 56-62 HRC	 Quality standards UDT-CERT ISO 14001 ISO 9001	 Fine brush FINE BRUSH

PICTOGRAMS

















































































































 Inner diameter	 Force adjustment	 Accuracy class	 Hardened steel	 Stone	 Abrasion resistant
 Drying time	 Metal hoising	 2 scales	 Aluminum construction	 Steel	 Cut resistant
 3 layers	 Staples view	 Nylon coated	 Solid construction	 Rubber	 Latex
 Filtration class	 Steel rivets	 Nylon guard	 Cutting wheel diameter	 Waterproof	 Strong rubber
 Tear resistant	 Aluminum rivets	 Steel tape	 Hole diameter	 Washable	 Construction works
 Car tester	 4 tips	 Double protect	 Cutting wheel thickness	 For black boards	 Gripping precision
 Microwave leakage test	 Diameter adjustment	 Measurement accuracy	 Screw included	 Plastic	 Reinforced construction
 AC test	 Handle opening lock	 Temperature range	 Tungsten File	 Paintings	 2 organizers
 Continuity test	 Stainless rivets	 Resistance UV	 Half-round cross-section	 Reinforcing mesh	 Metal buckle
 Bent jaws	 Steel rivets	 Shock protect	 2 scraper blades	 Tensile strength	 Drawer with handle
 Side blades	 Aluminum rivets	 Slope measurement	 Scraper blade thickness	 Rough surfaces	 Blade width
 Nut grip	 Force adjustment	 Strong weld	 Thickness of 2 scraper blades	 Easy to tear	 Quick blade change
 Narrowed jaws	 Jaws opening	 Felt	 Tiles thickness range	 Surface	 Double sharpening
 Cable cutting	 Pressure force	 Aluminium	 Min. grout thickness	 Clean the gluing surface	 Shears jaw hardness
 Clamping force adjustment	 Drilling	 Rubber	 Solid construction	 Sticky lasts for 14 days	 Two-component grip
 Working range of jaws	 Machine cutting	 Cube cut	 Aluminum trigger	 Resistance UV	 Steel frame
 Jaws width	 Painting nuts and bolts	 Sponge pad	 Writing line thickness	 Spray painting	 2 cutting angles
 Jaws opening	 Painting rims	 Hardened steel	 Glass	 Leather	
 Working range of jaws	 Temperature resistance	 Powder coated	 Wood	 Tear resistance	

TABLE OF CONTENTS



























		page
POWER TOOLS		10
Drills, mixers, hammer drills		13
Cordless tools		19
Angle grinders		27
Finishing works		31
Hot air guns		34
Glue guns and soldering irons		36
Woodworking tools		38
Vacuum cleaners		42
Other powertools		44
POWER TOOL ACCESSORIES		48
Bits		50
1/4" drive sockets		53
1/4" bit holders		54
Metal drill bits		57
Wood drill bits		59
Glass drill bits		60
Concrete drill bits		61
SDS plus drill bits and chisels		61
SDS max drill bits		63
Diamond holesaws and crowns		64
Crown holesaws		65
Drill chucks and adapters		66
Saw blades for reciprocating saw and jig saws		67
Abrasives and polishing materials		69
Sanding discs		71
Cutting and grinding discs		71
Stirring paddles		75

TABLE OF CONTENTS

























		page
Wire brushes		76
Welding rods, solders, glues		78
Vacuum cleaner bags		79
BASIC TOOLS		80
Screwdrivers and multi-screwdrivers		82
VDE insulated screwdrivers		86
Voltage testers		87
VDE insulated tools		89
Wire strippers		91
Cable and wire rope cutters		92
Crimping pliers for electrical connectors and terminals		93
Pliers, cutters, pincers		94
Adjustable wrenches		100
Hammers and axes		104
Vices and clamps		107
CONNECTING TOOLS		108
Staplers		111
Staples		111
Riveters		112
Manual benders for drywall sections		113
MECHANICAL TOOLS		114
Open-end and combination wrenches		117
Knobs and ratchets		120
Sockets		122
Toolkits		123
Adjustable and wheel lug wrenches		124
Allen keys		125

TABLE OF CONTENTS























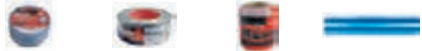

		page
Straps and slings		127
Technical chemistry		127
MEASURING TOOLS		130
Folding rulers		133
Tape rulers		133
Measuring tapes		135
Square rulers		135
Slide callipers		137
CONSTRUCTION TOOLS		138
Levels		141
Bricklayer staffs and bricklayer's squares		141
Sanding sponges		142
Scrapers and spatulas		143
Trowels		145
Floats		149
Tile cutters		153
Tiling tools		154
Application guns		156
Pencils, chalks, markers		157
Tapes and foils		159
Hooks and crowbars		161
Padlocks		161
Shovels, spades, pitchforks, rakes		161
Broomers		164
Gloves		164
Protective helmets		166
Masks and face shields		167
Protective ear muffs and knee pads		168

TABLE OF CONTENTS

		page
TOOL TRANSPORT ACCESSORIES		169
Tool boxes		170
Tool bags		171
Tool belts and belt accessories		172
CUTTING TOOLS		176
Knives and blades		178
Shears		183
Chisels		186
PVC pipe cutters		186
Taps and dies		187
Saws and saw blades		188
LIST OF INDEXES		192



**MODECO EXPERT | POWER TOOLS, HAND TOOLS,
POWER TOOL ACCESSORIES**
A solid brand you can rely on

You set the goal – we help you achieve it. For 30 years, as the Modeco Expert brand, we have been providing a wide range of high quality tools, tailor-made to fit our customers' specific needs.

Trust cannot be bought, it has to be earned. At Modeco Expert, we have been doing this for over three decades, consistently monitoring the needs of our customers and incessantly introducing improvements and totally new products. We set

OFFER



the bar very high, but we nevertheless keep pushing the boundaries every year in terms of quality, reliability, ergonomics, and comfort of work with our tools.

In the latest catalogue, you will find products that are suitable for a wide range of applications and meet the expectations of many user groups, from amateur DIY enthusiasts to professionals working in renovation or at construction sites on a daily basis. To make it easier to choose, we divided our extensive range clearly into the following categories: Power Tools and Power Tool Accessories, Basic Tools, Connection Tools, Mechanical Tools and Automotive Articles, Measuring Tools, Building Tools and

Tool Transport Accessories, and Cutting Tools. After more than thirty years of uninterrupted presence on the market, we enjoy not only the fully deserved trust of a huge group of regular customers who keep coming back to us, but also steadily growing interest on the part of new ones, representing yet another generation of enthusiasts and experts who can appreciate high-quality tools. It is clear that world is changing, but certain things, such as durability, reliability, and safety of use, are not losing, but actually gaining in value. This is the case especially when the manufacturer is capable of expanding traditional solutions by adding an appropriate portion of significant innovations

– this is, after all, one of the main driving forces behind Modeco Expert.

We are absolutely certain that the robustness of any modern brand is measured also by its comprehensive approach to the range offered, in which the product is almost as important as the service associated with it. We are therefore delighted to remind you that you can count on the knowledge, experience and skills of our indispensable sales representatives and service technicians at all times. Meanwhile, you are most welcome to read our latest catalogue and find out more about the current offering.

The Modeco Expert Team

POWERTOOLS

The Modeco Expert power tools portfolio is designed for a wide range of users. These devices meet the expectations of both beginners and advanced DIYers, offering best-in-class performance on a daily basis.

The design of the Modeco Expert power tools is based on proven technical solutions combined with great attention to technical inspection at every stage of production. Good concept and use of top-quality materials along with meticulous quality control guarantee failure-free operation and user satisfaction. The Modeco Expert brand also provides the customers with after-sales service according to the highest standards. In the warranty period, the Modeco Expert technical support unit ensures quick and professional troubleshooting and elimination of defects. Once the warranty period lapses, the Modeco Expert technical support services make sure that spare parts are available for all models currently on the offering, but also for discontinued equipment. We also provide technical advice and assistance in choosing the right spares for our products. One of the most attractive lines of the Modeco Expert power tools is the 18V Modeco System family of battery-powered devices, offering users a wide range of diversified equipment powered by one type of 18V Li-ION battery. They are characterised by state-of-the-art solutions, high performance, and impressive durability.





IMPACT DRILLS ELECTRIC MIXERS

The Modeco Expert drills and stirrers are proven designs offering parameters tailored to the needs of demanding users, including DIYers, installers, carpenters, electricians, bricklayers, and tile setters.

The drills are intended for both non-percussion drilling in metal, wood, and plastics, and percussion drilling in materials such as lightweight concrete, masonry, brick, and stone. Stirrers, on the other hand, provide the support you need when mixing mortar, paint, and plaster. The high quality of the components used in the products of this family guarantees their reliability.

A product that stands out in the Modeco Expert offering is the MN-90-035 850W universal hammer drill. Its main advantages include the aluminium body, which increases the device's durability and improves heat dissipation, and the 1.5–13mm drill chuck, allowing you to use a wide range of drills and matching accessories.

▶ **RIGHT/LEFT ROTATION CHANGE** making it possible to remove drill bits as well as screws and bolts from materials more easily

3 METRES LONG CABLE ◀ providing the operator with freedom to work without having to carry the power source

ALUMINIUM BODY ◀ for improved tool durability and heat dissipation

▶ **ROTATIONAL SPEED CONTROL** allowing you to adjust the tool's parameters to the job at hand

▶ **SIDE HANDLE CONNECTING PIECE MADE OF METAL**, enabling you to apply greater force to the material being drilled in thanks to increased material strength



index		5906675
	pcs	
MN-90-031	1	390444



drilling
hammer drilling
left/right
rotation switch
speed control

Accessories:
chuck key
side handle
depth limiter

Power	600 W
chuck type	1,5-13 mm
rotation speed	0-3 000 /min
impact frequency	48 000 /min
drilling capacity:	
wood	max. ø25 mm
metal	max. ø10 mm
concrete	max. ø13 mm

IMPACT DRILL 600W



POWER TOOLS

index		5906675
	pcs	
MN-90-032	1	390468



drilling
hammer drilling
keyless drill chuck
left/right
rotation switch
speed control

Accessories:
side handle
depth limiter
plastic case

Power	600 W
chuck type	1,5-13 mm
rotation speed	0-3 000 /min
impact frequency	48 000 /min
drilling capacity:	
wood	max. ø25 mm
metal	max. ø10 mm
concrete	max. ø13 mm

IMPACT DRILL 600W



index		5906675
	pcs	
MN-90-033	1	390475



drilling
hammer drilling
left/right
rotation switch
speed control

Accessories:
chuck key
side handle
depth limiter

Power	710 W
chuck type	1,5-13 mm
rotation speed	0-3 000 /min
impact frequency	48 000 /min
drilling capacity:	
wood	max. ø25 mm
metal	max. ø10 mm
concrete	max. ø13 mm

IMPACT DRILL 710W



IMPACT DRILL 800W



index		5906675
	pcs	
MN-90-034	1	390482



drilling
hammer drilling
left/right
rotation switch
speed control

Accessories:
chuck key
side handle
depth limiter

Power	800 W
chuck type	1,5-13 mm
rotation speed	0-3 000 /min
impact frequency	48 000 /min
drilling capacity:	
wood	max. ø30 mm
metal	max. ø13 mm
concrete	max. ø13 mm

IMPACT DRILL 850W



index		5906675
	pcs	
MN-90-035	1	390499



drilling
hammer drilling
left/right
rotation switch
speed control

Accessories:
chuck key
side handle
depth limiter

Power	850 W
chuck type	1,5-13 mm
rotation speed	0-3 000 /min
impact frequency	48 000 /min
drilling capacity:	
wood	max. ø30 mm
metal	max. ø13 mm
concrete	max. ø13 mm

MIXER 850W



index		5906675
	pcs	
MN-90-104	1	076935



speed control
metal body

Accessories:
mixing paddle
wrench set

Power	850 W
mixing paddle diameter	max. ø120 mm
mixing paddle fixing	M14x2
rotation speed:	0-500 /min.
cord length	3 m

index		5906675
	pcs	
MN-90-105	1	076942

CE

speed control
2 gears
metal body

Accessories:
mixing paddle
wrench set

Power	1 400 W
mixing paddle diameter	ø140 mm
mixing paddle fixing	M14
rotation speed:	
I gear	0-480 /min.
II gear	0-800 /min.
cord length	3 m

MIXER 1400W



POWER TOOLS

index		5906675
	pcs	
MN-90-107	1	076959

CE

speed control
2 gears
2 stirring paddles
metal body

Accessories:
2 mixing paddle

Power	1 600 W
mixing paddle diameter	2x ø120 mm
mixing paddle fixing	HEX13
rotation speed:	
I gear	200-480 /min.
II gear	250-680 /min.
cord length	3 m

MIXER 1600W



HAMMER DRILLS

Drilling in hard construction materials requires adequate power tools. The Modeco Expert brand delivers a range of modern SDS-Plus rotary hammers for demanding users. The high performance of the hammer mechanisms we use and the quality of workmanship will satisfy demanding DIYers and craftsmen.

Among the most popular solutions from Modeco Expert is the MN-90-222 800W SDS-plus rotary hammer. It is suitable for a wide range of applications thanks to its replaceable chuck. Featuring an electro-pneumatic impactor, it ensures high energy of the drill bit impact which translates into increased drilling speed. Another advantage of the rotary hammer is a feature which allows you to unlock the chisel position in the chuck and so adjust the chisel working angle.

▶ **FOUR OPERATING MODES (DRILLING, HAMMER DRILLING, CHISELING AND TILE REMOVAL, CHISEL ROTATION)** for versatile power tool application

▶ **CONVENIENT QUICK CHUCK CHANGE SYSTEM** allowing you to use cylindrical drill bits

ROTATIONAL SPEED CONTROL ◀ allowing you to adjust the tool's parameters to the job at hand

RUBBER CABLE INSULATION ◀ for improved mechanical damage resistance, meaning longer service life



index		5906675
	pcs	
MN-90-211	1	158532



drilling
hammer drilling
chiseling
left/right rotation switch
speed control

Accessories:
keyless drill chuck
side handle
depth limiter
3 drill bits SDS-Plus
2 chisels SDS-Plus
carrying case

Power	620 W
chuck's type:	SDS-Plus, 13 mm
drilling capacity:	
wood	max. ø30 mm
steel	max. ø13 mm
concrete	max. ø22 mm
rotation speed	0-1 250/min.
impact energy	2,1 J
impact frequency	0-5 200/min.
cord length	2 m

SDS-PLUS HAMMER DRILL 620W



POWER TOOLS

index		5906757
	pcs	
MN-90-221	1	001268



drilling
hammer drilling
chiseling
left/right rotation switch
speed control

Accessories:
side handle
depth limiter
carrying case

Power	800 W
chuck's type:	SDS-Plus
drilling capacity:	
wood	max. ø30 mm
steel	max. ø13 mm
concrete	max. ø26 mm
rotation speed	0 - 1 350/min.
Impact energy	2,8 J
impact frequency	0-5 600/min.
cord length	3 m

SDS-PLUS HAMMER DRILL 800W



index		5906757
	pcs	
MN-90-222	1	001275



drilling
hammer drilling
chiseling
left/right rotation switch
speed control

Accessories:
keyless drill chuck
side handle
depth limiter
3 drill bits SDS-Plus
2 chisels SDS-Plus
carrying case

Power	800 W
chucks:	SDS-Plus, 13 mm
drilling capacity:	
wood	max. ø30 mm
steel	max. ø13 mm
concrete	max. ø26 mm
rotation speed	0-1 350/min.
impact energy	2,8 J
impact rate	0-5 600/min.
cord length	3 m

SDS-PLUS HAMMER DRILL 800W



SDS-PLUS HAMMER DRILL 900W



index		5906757
	pcs	
MN-90-223	1	001282



drilling
hammer drilling
chiseling
left/right rotation switch
speed control

Accessories:
side handle
depth limiter
3 drill bits SDS-Plus
2 chisels SDS-Plus
carrying case

Power	900 W
chuck's type:	SDS-Plus
drilling capacity:	
wood	max. ø30 mm
steel	max. ø13 mm
concrete	max. ø30 mm
rotation speed	0-1 100/min.
Impact energy	3,2 J
impact frequency	0-5 300/min.
cord length	3 m

SDS-PLUS HAMMER DRILL 900W



index		5906757
	pcs	
MN-90-252	1	7000537



drilling
hammer drilling
chiseling

Accessories:
additional key chuck
through SDS-Plus system
spare brushes
side handle
depth limiter
2 chisels
3 drill bits SDS-Plus
grease for SDS-Plus bits
carrying case

Power	900 W
chuck capacity	SDS-Plus
drilling capacity:	
wood	max. ø40 mm
steel	max. ø13 mm
concrete	max. ø26 mm
speed	880 obr./min.
impact energy	4,2 J
impact rate	4 300/min
cord length	3 m

CORDLESS POWER TOOLS



Cordless Devices solutions are growing in popularity among power tool users. To meet the expectations of DIYers, Modeco Expert offers a wide range of power tools powered by lithium-ion batteries. The all new Modeco System 18V LI-ION line comprises a wide selection of state-of-the-art power tools while ensuring full compatibility of batteries and chargers.

The 18V LI-ION Modeco System guarantees quality and durability of the power tools and allows you to save money at the same time. What the system also stands for is an impressive diversity of configurations and the users' capacity to define the tool's technical parameters – they can easily choose the right power tool and equip it with the selected battery pack and charger of their choice.



CORDLESS TOOL SET 12V LI-ION



index		5906675
	pcs	
MN-91-501	1	028170



screwdriving
drilling
cutting
polishing
scraping
left/right
LED light

Accessories:
combi drill
multitool
Flashlight LED
2 batteries 12V, 1.5Ah
case

Battery	Li-ion 12 V
battery charging time	1 h
chuck capacity	0,8-10 mm
drilling capacity:	
wood	max. ø16 mm
metal	max. ø6 mm
oscillations	2 700-16 000/min.
light output	100 lm

18V LI-ION BATTERY



index		5906757
	pcs	
MN-91-130	1	001466

LI-ION 18 V
MODECO SYSTEM

compatible with MODECO SYSTEM 18V
fast charging
battery level indicator

Battery	Li-ion
Voltage	18 V
Capacity [Ah]	1,5 Ah
Capacity [Wh]	27 Wh
Charging time	30 min
Net weight	0,38 kg

18V LI-ION BATTERY



index		5906757
	pcs	
MN-91-131	1	001473

LI-ION 18 V
MODECO SYSTEM

compatible with MODECO SYSTEM 18V
fast charging
battery level indicator

Battery	Li-ion
voltage	18 V
capacity [Ah]	2,0 Ah
capacity [Wh]	36 Wh
charging time	45 min
net weight	0,38 kg

index		5906757
	pcs	
MN-91-132	1	001480

LI-ION 18 V
MODECO SYSTEM

compatible with MODECO SYSTEM 18V
fast charging
battery level indicator

Battery	Li-Ion
voltage	18 V
capacity [Ah]	3,0 Ah
capacity [Wh]	54 Wh
charging time	65 min
net weight	0,6 kg

18V LI-ION BATTERY



index		5906757
	pcs	
MN-91-133	1	001497

LI-ION 18 V
MODECO SYSTEM

compatible with MODECO SYSTEM 18V
fast charging
battery level indicator

Battery	Li-Ion
voltage	18 V
capacity [Ah]	4,0 Ah
capacity [Wh]	72 Wh
charging time	90 min
net weight	0,6 kg

18V LI-ION BATTERY



index		5906757
	pcs	
MN-91-134	1	001503

LI-ION 18 V
MODECO SYSTEM

compatible with MODECO SYSTEM 18V
fast charging
electronic control charging process

supply voltage	230 V
charging current	4,0 A
charging time:	
battery 1,5 Ah	20 min
battery 2,0 Ah	30 min
battery 3,0 Ah	40 min
battery 4,0 Ah	55 min
net weight	0,65 kg

18V BATTERY CHARGER



NEW

index		5906757
	pcs	
MN-91-135	1	001510

LI-ION 18 V
MODECO SYSTEM

compatible with MODECO SYSTEM 18V
fast charging
electronic control charging process

supply voltage	230 V
charging current	2,4 A
charging time:	
battery 1,5 Ah	30 min.
battery 2,0 Ah	45 min.
battery 3,0 Ah	65 min.
battery 4,0 Ah	90 min.
net weight	0,4 kg

18V BATTERY CHARGER



18V DRILL / DRIVER



index		5906757
	pcs	
MN-91-136	1	001527

LI-ION 18 V
MODECO SYSTEM

compatible with MODECO SYSTEM 18V
two-speed gearbox
single sleeve chuck
fast battery charging

Equipment:
battery 1,5Ah
fast charger 2,4A
accessories
transport case

battery voltage	18 V
battery capacity	1,5 Ah
charging time	30 min.
number of batteries	1
max. torque	22 Nm
chuck capacity	1-10 mm
rotation speed:	
I gear	0-350 obr/min
II gear	0-1 300 obr/min
drilling diameter:	
wood	max. 20 mm
metal	max. 6 mm

18V DRILL / DRIVER



index		5906757
	pcs	
MN-91-137	1	001534

LI-ION 18 V
MODECO SYSTEM

compatible with MODECO SYSTEM 18V
two-speed gearbox
single sleeve chuck
fast battery charging

Equipment:
2 batteries 2,0Ah
fast charger 2,4A
accessories
transport case

battery voltage	18 V
battery capacity	2,0 Ah
charging time	45 min.
number of batteries	2
max. torque	40 Nm
chuck capacity	1-13 mm
rotation speed:	
I gear	0-450 obr/min
II gear	0-1 600 obr/min
drilling diameter:	
wood	max. 22 mm
metal	max. 10 mm

18V DRILL / DRIVER WITH IMPACT



index		5906757
	pcs	
MN-91-138	1	001541

LI-ION 18 V
MODECO SYSTEM

compatible with MODECO SYSTEM 18V
two-speed gearbox
single sleeve chuck
fast battery charging
hammer drilling function

Equipment:
2 batteries 2,0Ah
fast charger 2,4A
accessories
transport case

battery voltage	18 V
battery capacity	2,0 Ah
charging time	45 min.
number of batteries	2
max. torque	40 Nm
chuck capacity	1-13 mm
rotation speed :	
I gear	0-450 obr/min
II gear	0-1 600 obr/min
drilling diameter :	
wood	max. 22 mm
metal	max. 10 mm
concrete	max. 10 mm

index		5906675
	pcs	
MN-91-148	1	456362

LI-ION 18 V
MODECO SYSTEM

compatible with MODECO SYSTEM 18V
two-speed gearbox
single sleeve chuck

Equipment:
without battery
and charger

voltage	18 V
max. torque	28 Nm
chuck capacity	1-10 mm
rotation speed:	
I gear	0-400 obr/min
II gear	0-1350 obr/min
drilling diameter:	
wood	max. 20 mm
metal	max. 6 mm

18V DRILL / DRIVER



POWER TOOLS

index		5906757
	pcs	
MN-91-139	1	001558

LI-ION 18 V
MODECO SYSTEM

compatible with MODECO SYSTEM 18V
tool holder ¼" HEX
metal gear housing
without battery and charger

voltage	18 V
max. torque	180 Nm
tool holder	¼" HEX
rotation speed	0-2 800 obr/min
impact frequency	0-3 600/min
max. size of bolt	M12

18V IMPACT DRIVER



index		5906757
	pcs	
MN-91-140	1	001565

LI-ION 18 V
MODECO SYSTEM

compatible with MODECO SYSTEM 18 V
tool holder ½"
metal gear housing
without battery and charger

voltage	18 V
max. torque	350 Nm
tool holder	½"
rotation speed	0-2 300 obr/min
impact frequency	0-3 300/min
max. size of bolt	M16

18V IMPACT WRENCH



18V HAMMER DRILL SDS-PLUS



index		5906757
	pcs	
MN-91-141	1	001572

LI-ION 18 V
MODECO SYSTEM

compatible with MODECO SYSTEM 18V
tool holder SDS-plus
drilling
hammer drilling
rotations left/right
without battery and charger

voltage	18 V
chuck's type	SDS-Plus
impact energy	0,9 J
impact frequency	0-4 300/min
rotation speed	0-900 obr/min
drilling diameter:	
concrete	max. 10 mm
wood	max. 20 mm
metal	max. 10 mm

18V HAMMER DRILL SDS-PLUS



index		5906757
	pcs	
MN-91-142	1	001589

LI-ION 18 V
MODECO SYSTEM

compatible with MODECO SYSTEM 18V
tool holder SDS-plus
two-speed gearbox
drilling
hammer drilling
rotations left/right
without battery and charger

voltage	18 V
chuck's type	SDS-Plus
impact energy	1,2 J
impact frequency	0-5 000/min
rotation speed	
I gear	0-300 obr/min
II gear	0-1 000 obr/min
drilling diameter:	
concrete	max. 10 mm
wood	max. 20 mm
metal	max. 10 mm

18V ANGLE GRINDER



index		5906757
	pcs	
MN-91-143	1	001596

LI-ION 18 V
MODECO SYSTEM

compatible with MODECO SYSTEM 18V
tool-free adjustment disc cover
side handle mounted in 3 positions
key pocket mounted
in the handle
without battery and charger

voltage	18 V
disc diameter	115 mm
inner disc diameter	22,2 mm
rotation speed	8 000/min

index		5906757
	pcs	
MN-91-144	1	001602

LI-ION 18 V
MODECO SYSTEM

compatible with MODECO SYSTEM 18V
saw tilt adjustment up to 50°
adjusting the cutting depth
parallel guide
24-tooth circular saw blade
without battery and charger

voltage	18 V
saw blade diameter	165 mm
blade bore diameter	16 mm
rotation speed	3 800/min
max. cutting depth:	
angle 90°	50 mm
angle 45°	35 mm

index		5906757
	pcs	
MN-91-146	1	001626

LI-ION 18 V
MODECO SYSTEM

compatible with MODECO SYSTEM 18V
base tilt adjustment up to 45°
keyless base adjustment
stroke speed control
quick blade change
pendulum action
parallel guide
without battery and charger

voltage	18 V
blade holder type	typ „T“
stroke frequency	0-2400/min
stroke length	25,4 mm
max. cutting depth:	
wood	80 mm
metal	6 mm

index		5906757
	pcs	
MN-91-147	1	001633

LI-ION 18 V
MODECO SYSTEM

compatible with MODECO SYSTEM 18V
quick blade change
stroke speed control
keyless base adjustment
pendulum action
without battery and charger

voltage	18 V
stroke frequency	0-2 400/min
stroke length	20 mm
max. cutting depth:	
wood	150 mm
metal	5 mm

18V CIRCULAR SAW



JIGSAW 18V



RECIPROCATING SAW 18V



TOOL BAG



index	①	📦	📦	5906757
	mm	pcs	pcs	
MN-03-460	610x300x280	1	10	910287

LI-ION 18 V
MODECO SYSTEM

POLYESTER
600

27
POCKETS



compatible with MODECO SYSTEM 18V
made of strong polyester
reinforced seams
27 durable pockets
shoulder strap
zip closure

TOOL BAG



index	①	📦	📦	5906757
	mm	pcs	pcs	
MN-03-464	460x280x300	1	10	910294

LI-ION 18 V
MODECO SYSTEM

POLYESTER
600

30
POCKETS



compatible with MODECO SYSTEM 18V
made of strong polyester
reinforced seams
30 durable pockets
shoulder strap
zip closure
stiffened bottom

TOOL BAG



index	①	📦	📦	5906757
	mm	pcs	pcs	
MN-03-466	500x230x280	1	4	910300

LI-ION 18 V
MODECO SYSTEM

POLYESTER
600

23
POCKETS



compatible with MODECO SYSTEM 18V
made of strong polyester
reinforced seams
23 durable pockets
shoulder strap
metal handle

ANGLE GRINDERS



Angle grinders – representing one of the most popular groups of power tools on our market – are subject to demanding strength tests. The models delivered by Modeco Expert are designed to ensure robustness and reliability, without compromising cost-effectiveness at the same time. This means that they are perfect solutions for demanding DIYers and craftsmen looking for ergonomic products of good quality.

This group of power tools includes the versatile 1200W two-hand angle grinder matching 125mm discs with a speed control feature, designed for more demanding and prolonged applications. It has the advantage of an ergonomic two-hand construction with a rubberised anti-slip handle for improved comfort and safety.

▶ **3-POSITION SIDE HANDLE**
providing more secure grip, increased safety, and improved ergonomics as well as working precision

3 METRES LONG CABLE ◀
providing the operator with freedom to work without having to carry the power source



ERGONOMIC DESIGN ◀
with safety switch to prevent accidental start-up

ROTATIONAL SPEED CONTROL ◀
allowing you to adjust the tool's parameters to the job at hand

KEYLESS GUARD ATTACHMENT ◀
for quick position change without additional tools



ANGLE GRINDERS 600W



index		5906675
		pcs
MN-93-035	1	345079

CE

chuck lock
3 position mounted
side handle

Accessories:
fork spanner
side handle

Power	600 W
disc diameter	ø115 mm
blade bore	ø22.2 mm
speed	12 000 obr./min.
cord length	3 m

ANGLE GRINDERS 750W



index		5906675
		pcs
MN-93-036	1	345086

CE

chuck lock
keyless guard
3 position mounted side handle
Soft Start - gentle
increase of speed at
start-up

Accessories:
fork spanner
side handle

Power	750 W
disc diameter	ø125 mm
blade bore	ø22.2 mm
speed	12 000 obr./min.
cord length	3 m

ANGLE GRINDERS 850W



index		5906675
		pcs
MN-93-037	1	345093

CE

chuck lock
keyless guard
3 position mounted side handle
Soft Start - gentle
increase of speed at
start-up

Accessories:
fork spanner
side handle

Power	850 W
disc diameter	ø125 mm
blade bore	ø22.2 mm
speed	12 000 obr./min.
cord length	3 m

index		590675
	pcs	
MN-93-022	1	7907447



chuck lock
keyless guard
3 position mounted side handle

Accessories:
fork spanner
side handle
spare brushes

Power	900 W
disc diameter	ø125 mm
blade bore	ø22.2 mm
speed	12 000 obr./min.
cord length	3 m

index		5906675
	pcs	
MN-93-038	1	345109



speed control
easy brushes change
chuck lock
keyless guard
easy access to brushes
3 position mounted side handle
Soft Start - gentle increase of speed at start-up

Accessories:
fork spanner
side handle
spare brushes

Power	1 200 W
disc diameter	ø125 mm
blade bore	ø22.2 mm
speed	4 000-12 000 obr./min.
cord length	3 m

ANGLE GRINDERS 900W



ANGLE GRINDERS 1200W



ANGLE GRINDERS 2300W



index		590675
	pcs	
MN-93-011	1	7901650

CE

chuck lock
Soft Start - gentle increase of speed at start-up
rotating rear handle
keyless guard
3 position mounted side handle

Accessories:
fork spanner
side handle
spare brushes

Power	2 300 W
disc diameter	ø230 mm
blade bore	ø22.2 mm
speed	6 200 obr./min.
cord length	3 m

ANGLE GRINDERS 2350W



index		5906675
	pcs	
MN-93-039	1	345116

CE

chuck lock
Soft Start - gentle increase of speed at start-up
keyless guard
3 position mounted side handle

Accessories:
fork spanner
side handle
spare brushes

Power	2 350 W
disc diameter	ø230 mm
blade bore	ø22.2 mm
speed	6 500 obr./min.
cord length	3 m

FINISHING WORK



Modeco Expert provides systems intended for sanding of gypsum finish plaster. These products are designed specifically for gypsum drywall working. Our selection of rotary sanders comprises products for sanding of wall and ceiling surfaces as well as corners. The Modeco Expert vacuum cleaner for gypsum dust, on the other hand, is characterised by a compact design and high resistance to the harmful effects of gypsum dust.

A product which clearly stands out in our portfolio is the MN-93-225 600W giraffe-type drywall sander. Its definite advantage is the possibility of adjusting the handle length (1100 - 1650 mm) which makes sanding of ceilings and walls otherwise beyond the operator's reach convenient and safe. It is also important that the sander features a disc speed control system which allows you to adjust its working speed to the substrate and the job specificity. Additionally, the design of the hinged and motorised sanding disc unit allows the disc to evenly adhere to the material being sanded.



LOWER HANDLE that can be hooked onto a tool belt while work is conducted, freeing the operator's hands, which significantly reduces work fatigue

4-METRE POWER CABLE significantly expanding the working area without moving the power source

CIRCUMFERENTIAL SANDING DISC BRUSH preventing dust from escaping and reducing damage to the surface being sanded

▶ **FOLDING SANDER BODY AND ATTACHED TRANSPORT CASE** for convenient and safe handling and storage

▶ **DUST EXTRACTION SYSTEM** ensuring reduced dustiness inside the room and better working conditions once connected with a vacuum cleaner via an attached tube



DRYWALL SANDER 1220W



index		5906675
	pcs	
MN-93-220	1	076928



speed control
2 position mounted side handle
shoulder strap
pulled off front part of the casing for grinding the corners of the walls
suction of dust with
power adjustment

Accessories:
set of sand papers
side handle and shoulder strap
dust bag with hose
wrench

Power	1 220 W
disc diameter	ø215 mm
diameter of paper	ø215-225 mm
diameter of pipe	ø 32 mm
speed	1 500-2 300 obr./min.
cord length	4 m

DRYWALL SANDER 600W



index		5906675
	pcs	
MN-93-225	1	076911



length adjustment
speed control
folding
hose for vacuum cleaner

Accessories:
set of sand papers
suction hose for vacuum cleaner with reductions
wrench carrying case

Power	600 W
disc diameter	ø215 mm
diameter of paper	ø215-225 mm
diameter of pipe	ø32 mm
speed	600-1 500 obr./min.
total length	1 100-1 650 mm
cord length	4 m

VACUUM CLEANER FOR GYPSUM DUST



index		5906675
	pcs	
MN-94-153	1	454986



dedicated to cooperation with a gypsum finish grinder automatic filter cleaning vacuum cleaner resistant to gypsum dust washable filter bagless vacuum cleaner wet and dry work power socket for power tool connections

Equipment:
flexible suction hose 3m
telescopic suction pipe
floor nozzle
multifunctional nozzle
power tool adapter
washable filter

Power	1400 W
tank capacity	18 l
air flow	34 l/s
underpressure	18,5 kPa
length of hose	3 m
cord length	6 m

index		5906757
		pcs
MN-92-304	1	274419



0-45° table tilt
stainless steel table

Accessories:
template for 45° cut

Power	450 W
blade diameter	ø180 mm
blade bore	ø22,2 mm
speed	2950 obr./min.
depth of cut	35,0 mm
table size	385x395 mm
cord length	3 m

TABLE TILE SAW 450W



POWER TOOLS

HEAT GUNS, SOLDERING GUNS, GLUE GUNS

The Modeco Expert line of heat guns includes both step-adjusted tools and devices featuring advanced stepless electronic temperature and airflow control. All these models are characterised by high quality and ergonomics that cater to the users' requirements.

The Modeco Expert range of hot melt glue guns and soldering irons will meet the expectations of all those looking for an efficient tool for repair and decoration work.

They include the MN-94-010 2-speed heat gun with a capacity of 2 000W. It stands out for its 6-step parameter adjustment system, visualised by LCD screen, making it possible to adapt working temperature to the job at hand. The heat gun design enables you to set it vertically as a stationary device and to handle the material with two hands.

▶ **LIGHTWEIGHT AND DURABLE BODY**

ensuring robustness and reducing fatigue at work



TWO SPEEDS allowing you to adjust working temperature in the range of 50–350°C (with 50°C increments) and in the range of 100–600°C (with 100°C increments), respectively

▶ **AIR FLOW ADJUSTABLE TO 550 L/MIN IN BOTH SPEEDS**

providing high blowing power for more efficient work

▶ **DIVERSITY OF ACCESSORIES:**

4 nozzles, spatula and scraper allowing for a wide range of works to be conducted without having to buy additional tools

index		5906675
	pcs	
MN-94-008	1	099156



2-step heat and air-flow settings

Power	2 000 W
temperature:	
level I	350°C
level II	550°C
cord length	3 m

HOT AIR GUN 2000W



POWER TOOLS

index		5906675
	pcs	
MN-94-010	1	099170



2-step heat and air-flow settings
digital LCD panel
smooth airflow setting
smooth temperature setting

Accessories:
4 exchangeable nozzle, shave hook, paint scraper, case

Power	2 000 W
temperature:	
level I	50°C
level II	50-600°C
cord length	3 m

HOT AIR GUN 2000W



GLUE GUN 25 (50)W



index		5906757
	pcs	
MN-99-003	10	154629



Start power	50 W
Rated power	25 W
glue diameter	ø11-12 mm
heating time	6 min.
working temperature	170°C
cord length	1,35 m

GLUE GUN 15 (80)W



index		5906757
	pcs	
MN-99-005	10	154636



Start power	65 W
Rated power	15 W
glue diameter	ø11-12 mm
heating time	7 min.
working temperature	170°C
cord length	1,35 m

GLUE GUN 15 (80)W



index		5906757
	pcs	
MN-99-006	1	269163



Accessories:
10 glue sticks
carrying case

Start power	80 W
Rated power	20 W
glue diameter	ø11-12 mm
heating time	7 min.
working temperature	170°C
cord length	1,35 m

index		5906757
	pcs	
MN-99-206	1	271036

CE

spot illumination

Accessories:
interchangeable tips
solder
rosin
carrying case

Power	175 W
heating time	12 sec.
cooling time	48 sec.
working temperature	430°C
cord length	1,5 m

TRANSFORMER SOLDERING GUN 175W



POWER TOOLS

index		5906757
	pcs	
MN-99-207	1	907485

CE

spot illumination
three-range temperature
control

Accessories:
interchangeable tips
key
solder
rosin
carrying case

Power	200 W
heating time	12 sec.
cooling time	48 sec.
working temperature	70-500 °C
cord length	1,5 m

TRANSFORMER SOLDERING GUN 200W



WOODWORKING

Cutting, sanding, planing – you can effectively perform all these operations without hassle using the Modeco Expert power tools.

Our woodworking machines will prove perfect for larger refurbishment and construction jobs as well as more precise renovation and decoration work. Workshop vacuum cleaners will help you to keep the workplace tidy while increasing its comfort and safety at the same time.

The advanced MN-92-103 800W jigsaw featuring a laser guide and cutting adjustment clearly stands out in the Modeco Expert offering. The product's main advantage is the possibility of controlling the blade working speed, which enables precise control and adjustment of the device parameters to the material being cut.

▶ **TRANSPARENT BLADE GUIDE** for high-precision jigsaw handling in the material combined with user protection against splinters

SWITCH LOCK enables long-term work without having to keep the trigger pressed, which affects work comfort and safety



▶ **LASER CUTTING LINE GUIDE** making it easy to guide the device along the desired track

index		5906675
	pcs	
MN-92-014	1	306872



45° base tilt
steel base
parallel guide

Accessories:
185 mm carbide disk blade
guide

Power	1 200 W
RPM	4 700 obr./min.
depth of cut at 90°	0-65 mm
tilting	0-45°
blade diameter	ø185 mm
blade bore	ø20 mm
cord length	3 m

CIRCULAR SAW 1200W



POWER TOOLS

index		5906675
	pcs	
MN-92-015	1	306957



45° base tilt
aluminium base
parallel guide
laser guide

Accessories:
185 mm carbide disk blade
guide

Power	1 500 W
RPM	4 700 obr./min.
depth of cut at 90°	0-63 mm
tilting	0-45°
blade diameter	ø185 mm
blade bore	ø20 mm
cord length	3 m

CIRCULAR SAW 1500W



index		5906675
	pcs	
MN-92-101	1	306155



± 45° base tilt
speed control
vacuum cleaner
connection

Accessories:
blade
guide

Power	400 W
blade	typ "T"
stroke rate	0-3000 /min
stroke length	18 mm
cutting degree	0-45°
cutting depth:	
wood	
metal	55 mm
aluminium	6 mm
cord length	6 mm
cord length	3 m

JIGSAW 400W



JIGSAW 570W



index		5906675
		pcs
MN-92-102	1	306407



± 45° base tilt
speed control
undercut adjustment
keyless blade change
vacuum cleaner connection

Power	570 W
blade	typ "T"
stroke rate	0-3 000 /min
stroke length	19 mm
cutting degree	0-45°
cutting depth:	
wood	
metal	65 mm
aluminium	8 mm
cord length	8 mm
cord length	3 m

JIGSAW 800W



index		5906675
		pcs
MN-92-103	1	306452



± 45° base tilt
speed control
undercut adjustment
keyless blade change
laser guide
vacuum cleaner connection

Power	800 W
blade	typ "T"
stroke rate	0-3 000/min.
stroke length	19 mm
cutting degree	0-45°
cutting depth:	
wood	
metal	80 mm
aluminium	10 mm
cord length	10 mm
cord length	3 m

SABRE SAW 800W



index		5906675
		pcs
MN-92-501	1	028132



Accessories:
blade

quick blade change
rotatable handle
LED light
keyless base adjustment

Power	800 W
stroke rate	0-2 800/min.
stroke length	28 mm
cutting depth:	
wood	150 mm
plastic	105 mm
aluminium	6 mm
steel	5 mm
cord length	3 m

index		5906675
	pcs	
MN-92-091	1	329178



cutting
polishing
scraping
oscillation

Accessories:

straight blade for metal cutting
round blade for wood cutting
scraper
polishing base
sanding paper (3 pcs)
dust extraction adapter
key
case

Power	300 W
oscillations	10 000-18 500/min.
cord length	3 m

MULTITOOL 300W



POWER TOOLS

index		590675
	pcs	
MN-93-210	1	7910355



aluminium base aluminium base алюминиевое основание

Accessories:
dust collector

Accessories:
dust collector

Принадлежности:
емкость для пыли

Power	300 W
pad size	115x230 mm
oscillations per minute	12 000/min.
oscillation travel	2 mm
cord length	3 m

FINISHING SANDER 300W



index		590675
	pcs	
MN-93-215	1	7910386



speed control
adjustable handle

Accessories:

dust collector
abrasive paper disk

Power	430 W
backing pad size	ø125 mm
speed	6 000-13 000 obr./min.
oscillation travel	2 mm
cord length	3 m

RANDOM ORBIT SANDER 430W



BELT SANDER 800W



index		5906675
	pcs	
MN-93-307	1	135885



Accessories:
dust collector
sanding belt
spare brushes

Power	800 W
belt speed	120-260 m/min.
sanding area	76x146 mm
belt dimensions	76x457 mm

PLANER 900W



index		5906757
	pcs	
MN-92-207	1	910409



chiseling depth limiter
chiseling depth adjustment
edge slot
aluminium base

Accessories:
spare brushes

Power	900 W
planer width	82 mm
depth of cut	0-3,0 mm
speed	16 000 obr. /min.
cord length	3 m

VACUUM CLEANER 18L 1200W



index		5906675
	pcs	
MN-94-151	1	383569



wet/dry
air outflow

Accessories:
suction hose
2 matching tubes
universal nozzle
flat nozzle
round nozzle
filter HEPA
dust bag

Power	1 200 W
capacity	18 l
intake airflow	1.75±0.1 m ³ /min
pressure	16±1.5 Kpa
rotation	2,5 m
cord length	5,2 m
dedicated dust bag	MN-94-193

index		5906675
		pcs
MN-94-152	1	383576



wet/dry
electric socket
air outflow

Accessories:

suction hose
2 matching tubes
Universal nozzle
flat nozzle
round nozzle
filter HEPA
dust bag

Power	1200 W
capacity	30 l
intake airflow	1.8±0.1 m ³ /min
pressure	17±1.5 Kpa
rotation	3 m
cord length	6 m
dedicated dust bag	MN-94-201

VACUUM CLEANER 30L 1200W



POWER TOOLS

index		5906675
		pcs
MN-94-153	1	454986



dedicated to cooperation with a
gypsum finish grinder
automatic filter cleaning
vacuum cleaner resistant
to gypsum dust
washable filter
bagless vacuum cleaner
wet and dry work
power socket for
power tool connections

Equipment:

flexible suction hose 3 m
telescopic suction pipe
floor nozzle
multifunctional nozzle
power tool adapter
washable filter

power	1400 W
tank capacity	18 l
air flow	34 l/s
underpressure	18,5 kPa
length of hose	3 m
cord length	6 m

VACUUM CLEANER FOR GYPSUM DUST



OTHER POWER TOOLS

The supplementary products from Modeco Expert include both highly specialised and universal devices that can be used for renovation work, at workshops or at home by DIYers.

One such product is the MN-93-015 150 W bench grinder. The compact size combined with an efficient, brushless motor ensures high durability and reliability of the device. An additional advantage is the aluminum body, which increases the durability of the device by effectively dissipating heat.

▶ **METAL BODY** increasing tool's durability and improving heat dissipation

LARGE ADJUSTABLE SCREENS ◀
protect the user from sparks and chippings and increase the safety of operation



▶ **150 W INDUCTION MOTOR,** due to, among others, the fact that it is brushless, ensures high durability and reliability of the tool

MOUNTING HOLES in the ◀
base allow the grinder to be fixed to a stable surface, which guarantees safe operation of the tool

index		5906675
	pcs	
MN-93-015	1	293400

CE

brushless motor
large, adjustable spark and chip
protective guards
aluminium body

brushless motor
large, adjustable spark and
chip protective guards
aluminium body

бесщеточный двигатель
большие регулируемые
экраны предохраняющие от искр и
осколков
алюминиевый корпус

Power	150 W
blade diameter	ø125 mm
blade bore	ø12,7 mm
grinding wheel width	16 mm
speed	2950 obr./min.
cord length	1,5 m

index		5906675
	pcs	
MN-93-016	1	293417

CE

brushless motor
large, adjustable spark and chip
protective guards
aluminium body

Power	350 W
blade diameter	ø200 mm
blade bore	ø16 mm
grinding wheel width	20 mm
speed	2950 obr./min.
cord length	1,5 m

BENCH GRINDER 150W



BENCH GRINDER 350W



POWER TOOLS

DIRTY WATER PUMP 750W



index		5906757
	pcs	
MN-95-005	1	909564



Submersible pump designed for pumping clean and dirty water
An adjustable length float switch turns the pump on and off according to the water level
The water connection allows the connection of hoses of various diameters

Power	750 W
max. immersion depth	7 m
max. lifting height	9 m
max. efficiency	13 000 l/h
min. water column height	9 cm
max. temperature of water	35°C
max. the size of the contamination	25 mm
cable length	10 m

DIRTY WATER PUMP 1100W



index		5906675
	pcs	
MN-95-006	1	014746



Submersible pump designed for pumping clean and dirty water
An adjustable length float switch turns the pump on and off according to the water level
The water connection allows the connection of hoses of various diameters

Power	1100 W
max. immersion depth	7 m
max. lifting height	11 m
max. efficiency	15 500 l/h
min. water column height	9 cm
max. temperature of water	35°C
max. the size of the contamination	25 mm
cable length	10 m

REEL EXTENSION CORD 25M



index		5906675
	pcs	
MN-99-922	1	022093



For indoor and outdoor use

cable length	25 m
cable profile:	3x1,5 mm ²
max power of connected devices:	
expanded cable	3 000 W
retracted cable	1 000 W



Power tools are relevant to both professionals and do-it-yourselfers, yet without properly fitted power tool accessories they cannot perform as expected.

POWER TOOL ACCESSORIES

That is why Modeco Expert have made sure that every user of the brand's power tools has also access to the necessary accessories. To meet the customers' requirements, the brand has created a series of bits, sockets and adapters. The offering includes PZ, PH, TORX, and HEX bits made of high quality S2 steel of hardness ranging at 56–62 HRC.

Modeco Expert also offers coated abrasive accessories, grinding discs, as well as corundum and diamond grinding wheels. Additionally, our portfolio has been extended with product groups that include cutting, bonding and mixing products. They stand out for their high quality which guarantees high performance and durability, which are all extremely important properties in products of this type.





BITS FOR POWER SCREWDRIVERS 25 MM PH2 BITS



index	+	↔	📦	📦	📦	5906757
		mm	pcs	pcs	pcs	
MN-15-302	PH2	25	20	240	2400	271739



25MM PZ2 BITS



index	+	↔	📦	📦	📦	5906757
		mm	pcs	pcs	pcs	
MN-15-312	PZ2	25	20	240	2400	271760



25MM PH2 BITS TIN TORSION



index	+	↔	📦	📦	📦	5906757
		mm	pcs	pcs	pcs	
MN-15-402	PH2	25	20	240	2400	271821



25MM PZ2 BITS TIN TORSION



index	+	↔	📦	📦	📦	5906757
		mm	pcs	pcs	pcs	
MN-15-412	PZ2	25	20	240	2400	271838





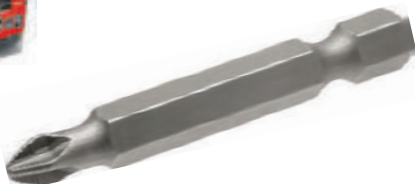

50MM PH BITS



index	+	↔	📦	📦	📦	5906757
		mm	pcs	pcs	pcs	
MN-15-391	PH2	50	10	120	1200	271869



index					5906757
		mm	pcs	pcs	
MN-15-393	PH2	100	12	480	271890
MN-15-394	PH2	150	12	480	271906
MN-15-395	PH2	200	12	480	271913
MN-15-396	PH2	250	12	240	271920
MN-15-398	PH2	350	12	216	271937



LONG PH BITS













index				5906757
	pieces	sets	sets	
MN-15-501	7	12	120	271708



7 PCS BIT SET SL, PH, PZ, 7 CZ.









			
		mm	mm
	⊕	5,0x0,8; 6,5x1,2	25
	⊕	PH1; PH2	25
	⊕	PZ1; PZ2	25
		1/4"	60



index				5906757
	pieces	sets	sets	
MN-15-502	7	12	120	271715



7 PCS BIT SET PH, PZ, 25 MM, 7 CZ.







			
		mm	mm
	⊕	PH0; PH1; PH2, PH3	25
	⊕	PZ1; PZ2	25
		1/4"	60



index				5906757
	pieces	sets	sets	
MN-15-511	5	12	120	271630



5 PCS BIT SET, 25 MM, 5 CZ.









			
		mm	mm
	⊕	PH0; PH1; 2x PH2; PH3	25

index				5906757
	pieces	sets	sets	
MN-15-512	5	12	120	271647



5 PCS BIT SET PH, PZ, 25 MM, 5 CZ.



			
		mm	mm
	⊕	PH1; PH2; PH3	25
	⊕	PZ1; PZ2	25

5 PCS BIT SET, 25 MM



index	①	📦	📦	5906757
	pieces	sets	sets	
MN-15-514	5	12	120	271661



	⌀	↔
	mm	mm
	⊕	H2; H3; H4; H5; H6
		25

5 PCS BIT SET, 25 MM



index	①	📦	📦	5906757
	pieces	sets	sets	
MN-15-515	5	12	120	271678



	⌀	↔
	mm	mm
	⊕	T10; T15; T20; T25; T30
		25

3 PCS BIT SET, 50 MM



index	①	📦	📦	5906757
	pieces	sets	sets	
MN-15-521	3	12	120	271685



	⌀	↔
	mm	mm
	⊕	PH1; PH2; PH3
		50

3 PCS BIT SET, 50 MM



index	①	📦	📦	5906757
	pieces	sets	sets	
MN-15-522	3	12	120	271692



	⌀	↔
	mm	mm
	⊕	PZ1; PZ2; PZ3
		50

PH2 BITS 25MM WITH STOP RING



index	⊕	↔	📦	📦	5906757
		mm	pcs	pcs	
MN-15-152	PH2	25	10	800	160477

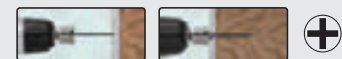

index					5906757
		mm	pcs	pcs	
MN-15-152-2	2xPH2	25	24	480	163805



2 BITS PH2 25 MM WITH STOP RING



index				5906675	
		pieces	sets	sets	
MN-15-540		32	6	24	135069

S2 STEEL

		mm	mm
		SL3, SL4, SL5	25
		2x PZ2	25
		2x PH2	25
		T10; T15; T20; T25; T27; T30; T40	25
		T10; T15; T20; T25; T27; T30; T40	25
		1/4"	60

32 PCS BIT SETS - SL, PH, PZ, TORX, 25 MM



index				5906675	
		pieces	sets	sets	
MN-15-541		15	15	60	092454

S2 STEEL

		mm	mm
		SL3, SL4, SL5	25
		PZ1, PZ2, PZ3	25
		PH1; PH2; PH3	25
		T10; T15; T20; T25; T30	25
		1/4"	60

15 PCS BIT SETS - SL, PH, PZ, TORX, 25 MM



index				5906675	
		pieces	sets	sets	
MN-15-542		15	15	60	092461

S2 STEEL

		mm	mm
		PH1; PH2; PH3; PZ1; PZ2; PZ3	25
		2xPH2, PH3, 2xPZ2	50
		T10; T20; T25; T30	25

15 PCS BIT SETS - PH, PZ, TORX



index					5906757	
	mm	inch	pcs	pcs		
MN-16-007	7,0	45	1/4	20	400	132627
MN-16-008	8,0	45	1/4	20	400	113589
MN-16-010	10,0	45	1/4	20	400	113596
MN-16-013	13,0	45	1/4	20	400	113602







SOCKETS DRIVE 1/4"



SOCKETS DRIVE 1/4"





index					5906757
		inch	pcs	pcs	
MN-16-006B	6,0	1/4	24	240	272613
MN-16-008B	8,0	1/4	24	240	272637
MN-16-010B	10,0	1/4	24	240	272644
MN-16-013B	13,0	1/4	24	240	272651



BIT HOLDER 1/4"



index					5906757
	mm	inch	pcs	pcs	
MN-16-105	60	1/4	24	288	160453







QUICK CHANGE BIT HOLDER 1/4"



MN-16-205





MN-16-207

index					5906757
	mm	inch	pcs	pcs	
MN-16-205	50	1/4	24	240	160484
MN-16-207	75	1/4	12	288	160491



QUICK CHANGE BIT HOLDER 1/4" 2 MAGNETS







index					5906657
	mm	inch	pcs	pcs	
MN-16-208	65	1/4	24	240	392943



BIT HOLDER 1/4"



index						5906757
		mm	mm	pcs	pcs	
MN-19-010	PH2	75	1/4	12	120	160514





index					5906675
	mm	inch	pcs	pcs	
MN-16-215	42	1/4	20	40	096971



ANGLE BIT HOLDER 1/4", BITY PH2 PZ2, 6CZ.



index				5906757
	pieces	pcs	pcs	
MN-62-390	5	10	100	270343

SCREW EXTRACTORS 5 PCS



	
	mm
	M3, M4, M5, M6, M8

DRILL BITS

Modeco Expert offers a portfolio of high-quality and durable drill bits that come in a wide range of sizes.

They can be used for drilling in steel and hard metals, concrete, stone, brick, hollow masonry units, or wood. Thanks to the variety of their applications, available sizes, as well as high quality, they can be successfully used by bricklayers, roofers, masons, fitters, and DIYers alike. Depending on the chuck type, the drill bits are intended for drills, cordless drill drivers as well as rotary hammers. The most popular products in the line are four-cutter drill bits for concrete, fitting into the SDS PLUS and SDS MAX chucks. They feature a characteristic monolithic four-cutter carbide tip that enables drilling in very hard concrete and a centring point allowing you to quickly start drilling without the bit slipping.



▶ **MONOLITHIC FOUR-CUTTER CARBIDE TIP** enabling you to drill in very hard concrete





▶ **SDS-PLUS and SDS-MAX CHUCK** ensuring that the product matches most of the rotary hammers available on the market

48-51 HRC HARDNESS ◀
for longer life

▶ **AUTOMATIC HARDENING AT 1200°C** that significantly increases material performance and strength

ADDITIONAL DRILL BIT SPIRAL GROOVE ◀
for faster extraction of drillings and increased drilling speed

DEEP-SEATED SINTERED CARBIDE ◀
element for prolonged service life

index					5906757
	mm	mm	pcs	pcs	
MN-60-230*	3,3	60	10	1000	267626
MN-60-240	4,0	75	10	1000	267657
MN-60-250	5,0	85	10	1000	267695
MN-60-260	6,0	95	10	1000	267718
MN-60-265	6,5	100	10	400	267725
MN-60-270	7,0	110	10	1000	267732
MN-60-280	8,0	115	10	1000	267749
MN-60-300	10,0	135	10	200	267756
MN-60-310	11,0	145	10	200	267763
MN-60-320	12,0	150	10	200	267770

* 2 pcs in pack



HSS-G GROUND METAL DRILL BIT









index				5906757
	pieces	sets	sets	
MN-60-904	6	1	100	267503



HSS-G GROUND METAL DRILL BIT SETU 2-8 MM, 6 PCS





		
	mm	mm
	2,0	50
	3,0	60
	4,0	75
	5,0	85
	6,0	95
	8,0	115

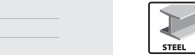

index				5906757
	pieces	sets	sets	
MN-60-906	13	10	100	267480

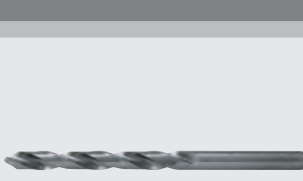

HSS-G GROUND METAL DRILL BIT SET 1,5-6,5 MM, 13 PCS





		
	mm	mm
	1,5	40
	2,0	50
	2,5	57
	3,0	60
	3,2	65
	3,5	70
	4,0	75
	4,2	75
	4,5	80
	5,0	85
	5,5	95
	6,0	95
	6,5	100



index				5906757
	pieces	sets	sets	
MN-60-911	10	10	100	267497



HSS-G GROUND METAL DRILL BIT SET 1-10 MM, 10 PCS



		
	mm	mm
	1,0	35
	2,0	50
	3,0	60
	4,0	75
	5,0	85
	6,0	95
	7,0	110
	8,0	115
	9,0	125
	10,0	135

index				5906757
	pieces	sets	sets	
MN-60-931	6	10	100	907263



METAL DRILL BIT SET 2-8 MM, 6 PCS

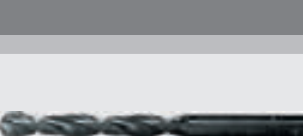

		
	mm	mm
	2,0	50
	3,0	60
	4,0	75
	5,0	85
	6,0	95
	8,0	115

METAL DRILL BIT SET 1,5-6,5 MM, 13 PCS

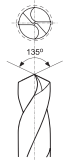

index	pieces	sets	sets	5906757
MN-60-932	13	10	100	907270



	mm	mm
	1,5	40
	2,0	49
	2,5	57
	3,0	61
	3,2	65
	3,5	70
	4,0	75
	4,5	80
	4,8	86
	5,0	86
	5,5	93
	6,0	93
	6,5	101



METAL DRILL BIT SET 2-8 MM, 13 PCS

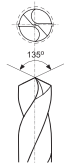

index	pieces	sets	sets	5906757
MN-60-933	13	10	100	907287



	mm	mm
	2,0	49
	2,5	57
	3,0	61
	3,5	70
	4,0	75
	4,5	80
	5,0	86
	5,5	93
	6,0	93
	6,5	101
	7,0	109
	7,5	109
	8,0	117



HSS-R METAL DRILL BIT SET 1-10 MM, 19 PCS

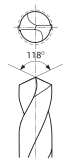



index	pieces	sets	sets	5906757
MN-60-934	19	1	40	907294



	mm	mm
	1,0	34
	1,5	40
	2,0	49
	2,5	57
	3,0	61
	3,5	70
	4,0	75
	4,5	80
	5,0	86
	5,5	93
	6,0	93
	6,5	101
	7,0	109
	7,5	109
	8,0	117
	8,5	117
	9,0	125
	9,5	125
	10,0	133







index				5906675
	mm	pcs	pcs	
MN-61-801	4, 5, 6, 7, 8, 9, 10, 11, 12	1	1	021034
MN-61-802	5, 7, 10, 13, 16, 19, 21, 23, 26, 29, 31, 33, 35	10	90	021041

TiN M2 STEEL

TAPERED DRILL BITS





index					5906757
	mm	mm	pcs	pcs	
MN-61-504	4,0	75	10	200	267831
MN-61-505	5,0	85	10	200	267848
MN-61-506	6,0	93	10	200	267855
MN-61-508	8,0	120	10	200	267879
MN-61-510	10,0	135	10	150	267893
MN-61-512	12,0	150	10	150	267909



BRAD POINT WOOD DRILL BITS









index				5906757
	pieces	sets	sets	
MN-61-571	5	10	120	267169



BRAD POINT WOOD DRILL BIT SET 4-10 MM, 5 PCS





		
	mm	mm
	4,0	75
	5,0	85
	6,0	93
	8,0	120
	10,0	135





index				5906757
	pieces	sets	sets	
MN-61-572	8	10	80	267176



BRAD POINT WOOD DRILL BIT SET 3-10 MM, 8 PCS



		
	mm	mm
	3,0	60
	4,0	75
	5,0	85
	6,0	93
	7,0	110
	8,0	120
	9,0	125
	10,0	135

index					5906757
	mm	mm	pcs	pcs	
MN-61-616	16,0	155	10	100	246171
MN-61-618	18,0	155	10	100	164734
MN-61-620	20,0	155	10	100	153004
MN-61-622	22,0	155	10	100	152984
MN-61-625	25,0	155	10	100	153028
MN-61-628	28,0	155	10	100	153080
MN-61-630	30,0	155	10	100	153035
MN-61-632	32,0	155	10	100	153042
MN-61-635	35,0	155	10	100	153059
MN-61-640	40,0	155	10	100	153066



FLATWOOD DRILL BITS



**FLATWOOD DRILL BIT SET
16-25 MM, 3 PCS**



index	①	📦	📦	5906757
	pieces	sets	sets	
MN-61-753	3	10	40	265189



	📏	📏
	mm	mm
	16,0	155
	20,0	155
	25,0	155

**FLATWOOD DRILL BIT SET
12-26 MM, 6 PCS**



index	①	📦	📦	5906757
	pieces	sets	sets	
MN-61-756	6	5	20	265196



	📏	📏
	mm	mm
	12,0	155
	16,0	155
	20,0	155
	22,0	155
	24,0	155
	26,0	155

CONFIRMAT SCREW DRILL BITS



index	📏	📏	📦	📦	5906757
	mm	mm	pcs	pcs	
MN-61-678	5,0	90	1	20	272309
MN-61-680	7,0	90	1	20	089396



SET MILLING CUTTERS WOOD 15-35 MM, 5 PCS



index	①	📦	📦	5906757
	pieces	sets	sets	
MN-61-760	5	5	20	000988





	📏	📏
	mm	mm
	15,0	88
	20,0	88
	25,0	88
	30,0	92
	35,0	92

GLASS DRILL BITS



index	📏	📏	📦	📦	5906757
	mm	mm	pcs	pcs	
MN-61-204	4,0	67	10	200	270770
MN-61-205	5,0	67	10	200	270787
MN-61-206	6,0	72	10	200	270794
MN-61-208	8,0	80	10	200	270800
MN-61-210	10,0	90	10	200	270817
MN-61-212	12,0	100	10	10	901759





index					5906757
	mm	mm	pcs	pcs	
MN-61-054	5,0	85	10	500	163287
MN-61-056	6,0	100	10	500	163294
MN-61-057	6,0	200	10	250	266377
MN-61-064	8,0	120	10	500	163300
MN-61-065	8,0	200	10	250	266384
MN-61-070	10,0	120	10	500	163317
MN-61-071	10,0	200	10	250	266391
MN-61-076	12,0	150	10	2000	163324
MN-61-077	12,0	200	10	1500	266407





GROUND CONCRETE DRILL BITS







index				5906757
	pieces	sets	sets	
MN-61-106	5	10	100	267466



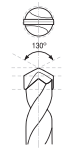

		
	mm	mm
	4,0	75
	5,0	85
	6,0	100
	8,0	120
	10,0	120

GROUND CONCRETE DRILL BIT SET 4-10 MM, 5 PCS









index				5906757
	pieces	sets	sets	
MN-61-109	8	10	100	267473

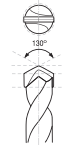

		
	mm	mm
	3,0	65
	4,0	75
	5,0	85
	6,0	100
	7,0	100
	8,0	120
	9,0	120
	10,0	120

GROUND CONCRETE DRILL BIT SET 3-10 MM, 8 PCS







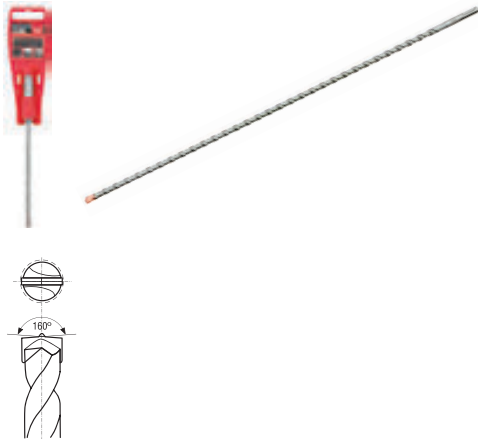

index						5906757
	mm	mm	mm	pcs	pcs	
MN-61-116	5	50	110	100	400	274341
MN-61-117	5	100	160	25	200	274358
MN-61-121	6	50	110	25	200	274020
MN-61-122	6	100	160	25	200	274037
MN-61-123	6	150	210	25	200	274044
MN-61-124	6	200	260	25	200	274051
MN-61-131	8	50	110	25	200	274068
MN-61-132	8	100	160	25	200	274075
MN-61-133	8	150	210	25	200	274082
MN-61-134	8	200	260	25	200	274099
MN-61-137	8	410	460	1	100	274105
MN-61-141	10	50	110	50	200	274112
MN-61-142	10	100	160	25	200	274129
MN-61-143	10	150	210	25	200	274136
MN-61-144	10	200	260	25	200	274143
MN-61-145	10	250	300	25	200	274150
MN-61-147	10	410	460	10	100	274167
MN-61-148	10	550	600	25	50	274174
MN-61-152	12	100	160	25	200	274181
MN-61-153	12	150	210	10	150	274198

SDS-PLUS DRILL BITS



SDS-PLUS DRILL BITS



index						5906757
	mm	mm	mm	pcs	pcs	
MN-61-154	12	200	260	25	200	274204
MN-61-155	12	250	300	25	100	274211
MN-61-157	12	410	460	25	100	274228
MN-61-158	12	550	600	25	50	274235
MN-61-163	14	150	210	10	150	274242
MN-61-165	14	250	300	20	100	274259
MN-61-167	14	410	460	10	50	274266
MN-61-168	14	550	600	10	50	274273
MN-61-175	16	250	300	20	100	274280
MN-61-177	16	410	460	10	50	274297
MN-61-178	16	550	600	10	50	274303
MN-61-187	18	410	460	10	50	274310
MN-61-197	20	410	460	10	30	274327







SDS-PLUS DRILL BITS 6-12 MM, 4 PCS







index				5906757
	pieces	sets	sets	
MN-61-202	4	10	100	902176



			
	mm	mm	mm
	6,0	100,0	160,0
	8,0	100,0	160,0
	10,0	100,0	160,0
	12,0	100,0	160,0

SDS-PLUS FLAT CHISELS







index					5906757
	mm	mm	pcs	pcs	
MN-61-091	20	250	50	100	907393
MN-61-092	40	250	50	100	907409



SDS-PLUS POINTED CHISEL







index					5906757
	mm	mm	pcs	pcs	
MN-61-093	—	250	50	100	907416



SDS-PLUS GOUGE CHISEL



index					5906757
	mm	mm	pcs	pcs	
MN-61-094	20	250	50	100	907423



index	5906675			pcs	pcs	5906675
	mm	mm	mm			
MN-61-902	5	50	110	25	200	412955
MN-61-903	5	100	160	25	200	412962
MN-61-904	6	50	110	25	200	412979
MN-61-905	6	100	160	25	200	412986
MN-61-906	6	150	210	25	200	412993
MN-61-907	6	200	260	25	200	413006
MN-61-908	8	50	110	25	200	413013
MN-61-909	8	100	160	25	200	413037
MN-61-910	8	150	210	25	200	413044
MN-61-911	8	200	260	25	200	413051
MN-61-937	8	250	310	25	200	001442
MN-61-938	8	300	360	25	200	001459
MN-61-912	8	410	460	25	100	413068
MN-61-913	10	50	110	25	200	413075
MN-61-914	10	100	160	25	200	413082
MN-61-915	10	150	210	25	200	413099
MN-61-916	10	200	260	25	200	413105
MN-61-917	10	250	300	25	200	413112
MN-61-918	10	410	460	25	100	413136
MN-61-919	10	550	600	25	50	413143
MN-61-920	12	100	160	25	200	413150
MN-61-921	12	150	210	25	200	413167
MN-61-922	12	200	260	25	200	413174
MN-61-923	12	250	300	25	100	413181
MN-61-924	12	400	450	25	100	413198
MN-61-925	12	550	600	25	50	413204
MN-61-926	14	150	210	20	200	413211
MN-61-927	14	250	300	20	100	413235
MN-61-928	14	400	450	10	50	413242
MN-61-929	14	550	600	10	50	413259
MN-61-930	16	250	300	20	100	413266
MN-61-931	16	400	450	10	50	413273
MN-61-932	16	550	600	10	50	413280
MN-61-933	18	400	450	10	50	413297
MN-61-934	20	410	460	10	40	413303



SDS-PLUS DRILL BITS



POWER TOOL ACCESSORIES

index	5906675			pcs	pcs	5906675
	mm	mm	mm			
MN-61-950	16	200	340	10	40	413310
MN-61-951	16	400	540	10	20	413334
MN-61-952	18	200	340	10	40	413341
MN-61-953	18	400	540	10	20	413358
MN-61-954	20	200	340	10	40	413365
MN-61-955	20	400	540	10	20	413372
MN-61-956	22	200	340	10	40	413389
MN-61-957	22	400	540	10	20	413396
MN-61-958	24	200	340	10	40	413402
MN-61-959	24	400	540	10	20	413419
MN-61-960	25	200	340	10	40	413433
MN-61-961	25	400	540	10	20	413440
MN-61-962	26	200	340	5	20	413457
MN-61-963	26	400	540	5	15	413464
MN-61-964	28	200	340	5	20	413471
MN-61-965	28	400	540	5	15	413488
MN-61-966	30	200	340	5	20	413495
MN-61-967	30	400	540	5	15	413501
MN-61-968	32	200	340	5	20	413518
MN-61-969	32	400	540	5	15	413525



SDS-MAX DRILL BITS



index	5906675			pcs	pcs	5906675
	mm	mm	mm			
MN-76-206	6	65	100	100	455266	
MN-76-208	8	65	100	100	455273	
MN-76-210	10	65	100	100	455280	
MN-76-212	12	65	100	100	455297	
MN-76-225	25	60	100	100	455303	
MN-76-235	35	60	5	50	455310	
MN-76-245	45	60	5	50	474762	
MN-76-255	55	60	5	50	474779	
MN-76-268	68	60	5	50	474786	

M14 shank







DIAMOND HOLE SAW - M14



DIAMOND HOLE SAW - HEX







index					5906675
	mm	mm	pcs	pcs	
MN-76-306	6	70	20	200	455228
MN-76-308	8	80	20	200	455235
MN-76-310	10	80	20	200	455242
MN-76-312	12	80	20	200	455259

HEX shank



DIAMOND HOLE SAWS SET - M14







index					5906675
	mm	mm	pcs	pcs	
MN-76-290	6, 8, 10, 12	65	10	60	7001404

M14 shank
M14/HEX adapter



DIAMOND HOLE SAWS SET - HEX



index					5906675
	mm	mm	pcs	pcs	
MN-76-294	5, 6, 8, 10, 12	70-80	10	60	7001398

HEX shank



DIAMOND HOLE SAW GUIDE



index			5906675
	pcs	pcs	
MN-76-298	5	50	455327







DIAMOND ROUTER



NEW

Available 09.2024

index					5906675
	mm	mm	pcs	pcs	
MN-76-315	10	45	25	100	556437
MN-76-316	20	45	25	100	556444

M14 shank





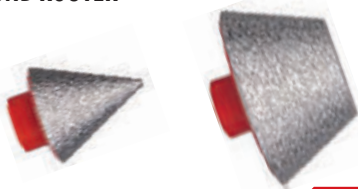

DIAMOND ROUTER



NEW

Available 09.2024





index					5906675
	mm	mm	pcs	pcs	
MN-76-317	5-50	45	15	60	556451
MN-76-318	35-75	45	10	40	556468

M14 shank

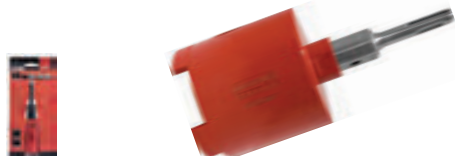





DIAMOND CROWNS



index					5906675
	mm	mm	pcs	pcs	
MN-61-240	62	80	5	20	014616
MN-61-241	82	80	5	20	014630

SDS-Plus shank
4 diamond segments





index					5906675
	mm	mm	pcs	pcs	
MN-61-246	10,0	120	1	30	014654

for diamond crowns
taper shank key for
removal



PILOT DRILL BIT



index					5906757
	mm	mm	pcs	pcs	
HEX					
MN-61-266	65	155	10	30	144842
MN-61-281	80	155	10	20	144859
SDS plus					
MN-61-366	65	155	10	30	151659
MN-61-381	80	155	10	20	151666

amount of sintered
carbides
ø65 mm-8 pcs
ø80 mm-10 pcs



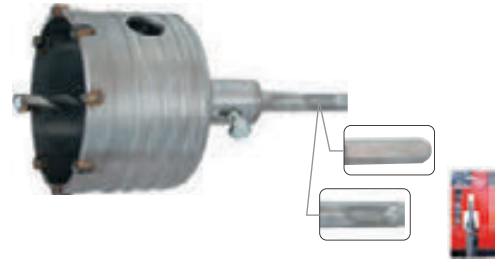

CORE DRILL BITS





index				5906757
	pieces	sets	sets	
MN-76-104	6	1	20	151604



	
mm	mm
33,0	65,0
53,0	65,0
67,0	65,0
83,0	65,0

HOLE SAW SET 33-83 MM, PCS





index				5906675
	mm	pcs	pcs	
MN-76-120	33,0; 43,0; 53,0; 67,0; 73,0; 83,0	10	50	014593



FIXING RING FOR HOLE SAWS 33-83 MM







index					5906675
	mm	mm	pcs	pcs	
MN-76-122	8,0	135	1	30	014609



PILOT DRILL BIT



index					5906675
	mm	mm	pcs	pcs	
MN-76-123	33,0	65	10	30	014548
MN-76-124	43,0	65	10	30	014661
MN-76-125	53,0	65	1	30	014555
MN-76-126	67,0	65	10	30	014562
MN-76-127	73,0	65	10	50	014579
MN-76-128	83,0	65	10	50	014586



HOLE SAW



CORE DRILL BIT



index					5906675
	mm	mm	pcs	pcs	
MN-61-406	22,0	52,0	10	360	900295
MN-61-408	25,0	52,0	1	360	900295
MN-61-411	30,0	52,0	10	180	900318
MN-61-413	35,0	52,0	1	180	900332
MN-61-417	44,0	47,0	1	120	900462
MN-61-420	51,0	47,0	10	120	900370
MN-61-423	64,0	47,0	1	120	900394
MN-61-427	73,0	47,0	10	60	900400
MN-61-434	102,0	47,0	1	60	900431



PILOT DRILL BIT



index				5906757
	mm	pcs	pcs	
MN-61-452	14-30	10	120	900479
MN-61-454	32-168	10	60	900486



HOLE SAW SET 51-102 MM, 9 PCS

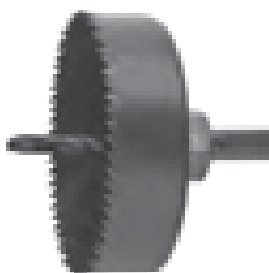

index				5906757
	pieces	sets	sets	
MN-65-621	9	1	20	248151



mm	mm
51	25
57	25
67	25
76	25
88	25
102	25

HOLE SAW SET 19-64 MM



index				5906757
	pieces	sets	sets	
MN-65-622	11	1	30	248168







mm	mm
19	25
22	25
29	25
35	25
38	25
44	25
51	25
64	25

SDS-PLUS ADAPTER - 1/2"







index			5906757
	pcs	pcs	
MN-61-395	1	120	163607

index					5906757
	mm	inch	pcs	pcs	
MN-97-043	1,5-13,0	1/2	6	30	268593

body made of ABS plastic
bottom part made of steel
additional blocking function
CLICK

KEYLESS DRILL CHUCKS CLICK 1,5-13 MM







index					5906675
	mm	mm	blister	blister	
MN-65-164	152	8,0	1	200	393100
MN-65-165	228	8,0	1	100	393117
MN-65-166	152	4,0	1	200	393124
MN-65-167	240	5,0	1	200	393131

packed
in 3 pieces in a blister

RECIPROCATING SAW BLADES



index					5906675
	mm	mm	blister	blister	
MN-65-168	152	1,8	1	200	393148
MN-65-169	150	1,0	1	200	393155
MN-65-170	228	1,8	1	200	393162







packed
in 3 pieces in a blister

packed
in 3 pieces in a blister

упаковано
в 3 штуки в блистере

RECIPROCATING SAW BLADES



index							5906757
	mm	mm	mm	description	blister	blister	
MN-65-182	76	51	1,2	C	1	100	907874
MN-65-183	76	51	2,0	C	1	100	907881
MN-65-184	76	51	1,2	B	1	100	907898
MN-65-185	100	75	3,0	F	1	100	907904

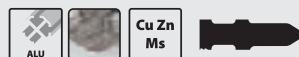

T-SHANK JIG SAW BLADES



T-SHANK JIG SAW BLADES



index							5906757
	mm	mm	mm	description	blister	blister	
MN-65-186	116	90	3,0	A	100	600	907911
MN-65-187	76	51	1,4	B	1	100	907928
MN-65-188	100	75	2,5	C	1	100	907935
MN-65-189	100	75	2,5	D	1	100	907942
MN-65-190	76	51	2,0	C	1	100	907959
MN-65-191	100	75	2,0	C	1	100	907966
MN-65-192	100	75	3,0	E	1	100	907973
MN-65-193	100	75	4,0	E	1	100	907980
MN-65-196	100	51	2,5	D	1	100	908017



T-SHANK JIG SAW BLADES



index							5906757
	mm	mm	mm	description	blister	blister	
MN-65-194	76	51	1,2	C	1	100	907997
MN-65-195	76	51	3,0	E	1	100	908000

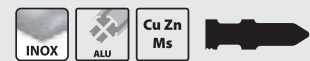

U-SHANK JIG SAW BLADES



index							5906757
	mm	mm	mm	description	blister	blister	
MN-65-197	100	75	3,0	F	1	100	908024

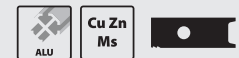

U-SHANK JIG SAW BLADES



index							5906757
	mm	mm	mm	description	blister	blister	
MN-65-198	100	75	3,0	C	100	400	908031

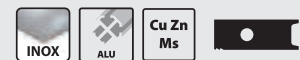

U-SHANK JIG SAW BLADES



index							5906757
	mm	mm	mm	description	blister/ блистер	blister/ блистер	
MN-65-199	100	75	2,5	A	1	100	908048
MN-65-200	100	75	2,5	D	1	100	908055
MN-65-201	100	75	3,0	C	1	100	908062





Legend for Jigsaw blades

- A** coarse cut
- B** curved cutting
- C** straight cut
- D** inverted tooth, for cutting MDF
- E** fast straight cutting
- F** fast curved cutting

index	🌀		📄	📦	📦	5906675
	mm	grain size				
MN-68-801	225	60	5	1	100	077260
MN-68-803	225	100	5	1	100	077277
MN-68-804	225	120	5	1	100	077284
MN-68-806	225	180	5	1	100	077291



SANDING DISCS
225 MM



index	type	🌀		📄	📦	📦	5906
		mm	grain size				
MN-68-540/5	HARD	225	40	5	120	600	675392981
MN-68-541/5	HARD	225	60	5	120	600	675392998
MN-68-542/5	HARD	225	80	5	150	750	675393001
MN-68-543/5	HARD	225	100	5	150	750	675393018
MN-68-544/5	HARD	225	120	5	150	750	675393025
MN-68-545/5	HARD	225	150	5	160	800	675393032
MN-68-546/5	HARD	225	180	5	170	850	675393049
MN-68-547/5	HARD	225	220	5	170	850	675393056



SANDING MESH DISCS
225 MM



index	type	🌀		📄	📦	📦	5906
		mm	grain size				
MN-68-548/5	SOFT	225	40	5	110	550	675393063
MN-68-549/5	SOFT	225	60	5	110	550	675393070
MN-68-550/5	SOFT	225	80	5	130	650	675393087
MN-68-551/5	SOFT	225	100	5	130	650	675393094
MN-68-552/5	SOFT	225	120	5	130	650	757275225
MN-68-553/5	SOFT	225	150	5	150	750	675394930
MN-68-554/5	SOFT	225	180	5	150	750	757275232
MN-68-555/5	SOFT	225	220	5	170	850	675394947



SANDING MESH DISCS
225 MM



SANDING DISCS 125 MM



index		grain size			5906757
	mm		pcs	pcs	
MN-68-470	125	24	50	1000	142817
MN-68-473	125	36	50	1000	086777
MN-68-476	125	40	50	1000	079519
MN-68-479	125	60	50	1000	080485
MN-68-482	125	80	50	1000	079502
MN-68-485	125	100	50	1000	079526
MN-68-488	125	120	50	1000	080492
MN-68-491	125	150	50	1000	079533
* packing 5 pcs.					
MN-68-470/5	125	24	1	200	265592
MN-68-473/5	125	36	1	200	265608
MN-68-476/5	125	40	1	200	265615
MN-68-479/5	125	60	1	200	265622
MN-68-482/5	125	80	1	200	265639
MN-68-488/5	125	120	1	200	265660



ENDLESS ABRASIVE PAPERS



index	grain size			5906757
		pcs	pcs	
MN-68-461/5	40	6	30	901117
MN-68-462/5	60	6	30	275041
MN-68-463/5	80	6	30	275058
MN-68-464/5	100	6	30	275065
MN-68-465/5	120	6	30	275072

dimensions 75x533 mm
5 pcs

index	grain size			5906757
		pcs	pcs	
MN-68-460/5	40	6	30	335650
MN-68-466/5	60	6	30	335667
MN-68-467/5	80	6	30	335674
MN-68-468/5	100	6	30	335698
MN-68-469/5	120	6	30	335704

dimensions 75x457 mm
5 pcs



POLISHING FELT DISCS 125 MM



index				5906757
	mm	pcs	pcs	
MN-68-620	125	1	20	082489





POLISHING WOOL DISCS 125 MM



index				5906757
	mm	pcs	pcs	
MN-68-622	125	1	20	082496





index				5906757
	mm	pcs	pcs	
MN-68-624	125	1	24	903722







POLISHING LAMB WOOL BONNETS 125 MM



index					5906757
	mm		pcs	pcs	
MN-68-611	125	M14	1	20	267329





FLEXIBLE BACKING PADS 125 MM



index					5906757
	mm	mm	pcs	pcs	
MN-68-605	125	8,0	20	80	082502





BACKING PADS 125 MM



index					5906757
	mm	mm	pcs	pcs	
MN-68-606	125	8,0	1	20	905528

BACKING PADS WITH JOINT 125 MM



index						5906757
	mm		mm	pcs	pcs	
MN-68-609	125	M14	8,0	20	100	267336

BACKING PADS OF LINING 125 MM



BACKING PADS 125 MM



index					5906757
	mm		pcs	pcs	
MN-68-608	125	M14	25	100	267312

DEPRESSED DISCS



index						5906757
	mm	mm	mm	pcs	pcs	
MN-68-902	125	22,23	3,0	25	200	162822
MN-68-905	230	22,23	3,0	25	50	162907



FLAT DISCS



index						5906757
	mm	mm	mm	pcs	pcs	
MN-68-907	300	32	3,0	5	25	162976
MN-68-908	350	32	3,0	5	25	162983
MN-68-909	400	32	3,0	5	25	162990



FLAT DISCS



index						5906757
	mm	mm	mm	pcs	pcs	
MN-68-961	115	22,23	1,0	25	500	904859
MN-68-962	125	22,23	1,0	25	500	904866
MN-68-966	115	22,23	1,6	25	500	904897
MN-68-967	125	22,23	1,6	25	500	904903
MN-68-965	230	22,23	1,9	25	50	904873



FLAT DISCS



index						5906757
	mm	mm	mm	pcs	pcs	
MN-68-911	115	22,23	1,0	25	500	162914
MN-68-912	125	22,23	1,0	25	500	162921
MN-68-915	230	22,23	1,9	25	100	270428
MN-68-916	115	22,23	1,6	25	500	904798
MN-68-917	125	22,23	1,6	25	500	904804



index						5906757
	mm	mm	mm	pcs	pcs	
MN-68-932	125	22,23	1,6	25	500	273603
MN-68-935	230	22,23	1,9	25	50	273627



ALUMINIUM CUTTING DISC



index						5906757
	mm	mm	mm	pcs	pcs	
MN-68-922	125	22,23	6,0	25	100	162945
MN-68-925	230	22,23	6,0	10	30	162969



METAL GRINDING DISC



index						5906757
	mm	mm	mm	pcs	pcs	
MN-68-942	125	22,23	3,0	25	200	162860
MN-68-945	230	22,23	3,0	25	50	162884



CONCRETE CUTTING DISC



index			grain size			5906757
	mm	mm		pcs	pcs	
MN-68-811	115	22,23	40	10	200	270244
MN-68-812	115	22,23	60	10	200	270251
MN-68-813	115	22,23	80	10	200	270268
MN-68-814	115	22,23	100	10	200	270275
MN-68-815	115	22,23	120	10	200	270282
MN-68-821	125	22,23	40	10	200	270299
MN-68-822	125	22,23	60	10	200	270305
MN-68-823	125	22,23	80	10	200	270312
MN-68-824	125	22,23	100	10	200	270329
MN-68-825	125	22,23	120	10	200	270336



FLAP SANDING DISCS 115/125MM

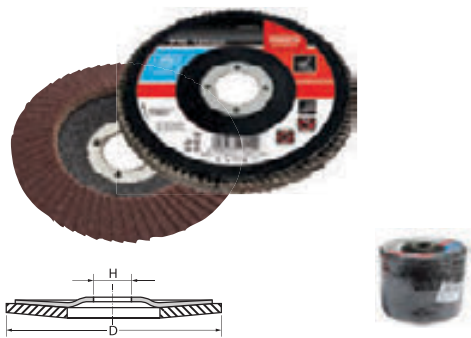

index			grain size			5906675
	mm	mm		pcs	pcs	
MN-68-831	115	22,23	40	10	200	420899
MN-68-832	115	22,23	60	10	200	420905
MN-68-833	115	22,23	80	10	200	420912
MN-68-834	115	22,23	100	10	200	420936
MN-68-835	115	22,23	120	10	200	420943
MN-68-841	125	22,23	40	10	200	420950
MN-68-842	125	22,23	60	10	200	420967
MN-68-843	125	22,23	80	10	200	420974
MN-68-844	125	22,23	100	10	200	420981
MN-68-845	125	22,23	120	10	200	420998



FLAP SANDING DISCS 115/125MM



DIAMOND BLADES



index					5906757
mm	mm	mm	pcs	pcs	
MN-78-132	115	22,23	10	100	267237
MN-78-133	125	22,23	10	100	267244
MN-78-135	230	22,23	10	20	267268



DIAMOND BLADES TURBO



index					5906757
mm	mm	mm	pcs	pcs	
MN-78-312	115	22,23	10	100	273788
MN-78-313	125	22,23	10	100	273795
MN-78-315	230	22,23	10	20	273818



DIAMOND BLADES



index					5906757
mm	mm	mm	pcs	pcs	
MN-78-212	115	22,23	10	100	273740
MN-78-213	125	22,23	10	100	273757
MN-78-215	230	22,23	10	20	273771



DIAMOND BLADES



index					5906757
mm	mm	mm	pcs	pcs	
MN-78-220	200	25,4/22,23	10	50	274440

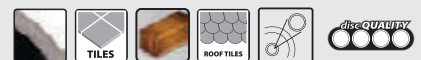

DIAMOND BLADES FOR GRINDING UNIVERSAL 125 MM



index					5906675
mm	mm	mm	pcs	pcs	
MN-78-411	125	22,23	10	40	022109



index					5906675
	mm	mm	pcs	pcs	
MN-78-412	125	22,23	10	40	022116



DIAMOND BLADES FOR GRINDING HEAVY DUTY 125 MM PRO

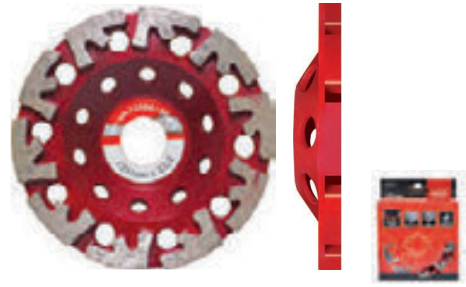

index					5906675
	mm	mm	pcs	pcs	
MN-78-413	125	22,23	10	40	022130



DIAMOND BLADES FOR GRINDING FAST 125 MM TURBO



index						5906757
	mm	mm	kg	pcs	pcs	
MN-79-061	80	400	5-15	1	10	146037
MN-79-063	100	500	15-25	1	10	146129



for emulsion, acryl,
dispersion paints
and stains

Hex Shank

STIRRING PADDLES TYPE A



index						5906757
	mm	mm	kg	pcs	pcs	
MN-79-069	80	400	1-10	1	10	146266
MN-79-071	100	500	10-20	1	10	146297
MN-79-073	120	600	16-35	1	10	146310

M14 Shank

index						5906757
	mm	mm	kg	pcs	pcs	
MN-79-081	100	600	10-20	1	10	902183
MN-79-082	120	600	16-35	1	10	272590
MN-79-083	135	600	20-40	1	6	902213

SDS+ Shank

index						5906757
	mm	mm	kg	pcs	pcs	
MN-79-074	100	600	10-20	1	10	033907
MN-79-080	120	600	16-35	1	10	151383



for adhesives,
tiles and thermal
insulation structural
plasters and mortars

Hex Shank

STIRRING PADDLES TYPE C



SET 2 TYPES C TYP TO THE MIXER



index					5906757
	mm	mm	pcs	pcs	
MN-79-089	100	540	1	4	000698



STIRRING PADDLES TYPE D DYNAMIC



index						5906757
	mm	mm	kg	pcs	pcs	
MN-79-078	80	400	10-20	1	10	155060
MN-79-079	100	500	15-30	1	10	155077



for adhesives for
tiles and thermal
insulation structural
plasters and mortars

STIRRING PADDLES TYPE E



index						5906757
	mm	mm	kg	pcs	pcs	
MN-79-075	80	400	10-15	1	8	146327
MN-79-077	100	500	12-30	1	8	146334

SDS+ Shank

	mm	mm	kg	pcs	pcs	
MN-79-076	100	500	16-25	1	8	089089

M14 Shank

	mm	mm	kg	pcs	pcs	
MN-79-093	120	600	16-35	1	10	902237



for plasters
putty plasters
gypsum plasters

Hex Shank

STIRRING PADDLES TYPE F



index						5906757
	mm	mm	kg	pcs	pcs	
MN-79-095	120	600	10-30	1	10	909731
MN-79-096	140	600	10-40	1	6	909748



for adhesives for tiles
and thermal insulation
structural plasters and
mortars





M14 shank

WIRE WHEELS



index					5906757
	mm	mm	pcs	pcs	
MN-69-142	115	22,23	12	48	269088
MN-69-144	150	22,23	12	48	269095







index					5906757
	mm	inch	pcs	pcs	
MN-69-172	65	1/4	12	96	269101
MN-69-173	75	1/4	12	96	269118
MN-69-175	100	1/4	12	96	269125



WIRE WHEELS







index					5906757
	mm	inch	pcs	pcs	
MN-69-191	50	1/4	12	96	269132
MN-69-193	75	1/4	12	96	269149



WIRE CUP BRUSHES







index					5906757
	mm	mm	pcs	pcs	
MN-69-164	80	M14	12	72	269064
MN-69-165	100	M14	12	48	269071



WIRE CUP BRUSHES







index					5906757
	mm	mm	pcs	pcs	
MN-69-112	115	M14	12	48	269002
MN-69-114	150	M14	12	24	269019



WIRE WHEELS



index					5906757
	mm	mm	pcs	pcs	
MN-69-121	100	M14	12	72	269040
MN-69-122	150	M14	12	48	269057



WIRE WHEELS



WIRE CUP BRUSHES



index					5906757
	mm	mm	pcs	pcs	
MN-69-134	80	M14	12	48	269026
MN-69-135	100	M14	12	48	269033



WELDING RODS 5KG



index				5906675
	mm	kg	kg	
MN-97-904	2,5	5	5	980270
MN-97-906	3,2	5	5	980577
MN-97-909	4,0	5	5	013732



SOLDERS 5KG



index				5906675
	pieces	kg	kg	
MN-97-960	15,5	5	5	962573



GLUE STICKS FOR GLUE GUNS GEN-T



index				5906757
	kg	pcs	pcs	
MN-97-980-1	1,00	1	1	906426
MN-97-980-5	5,00	1	1	906471
MN-97-980-B	0,10	1	10	906518



resistance to temp. -5°C setting time 35-40 sek.
 -5°C 35-40 sec.
 -5°C 35-40 cek.

przezroczysty transparent прозрачный

GLUE STICKS FOR GLUE GUNS PRO+



index				5906757
	kg	pcs	pcs	
MN-97-993-1	1,00	1	1	906747
MN-97-993-5	5,00	1	1	906495
MN-97-993-B	0,10	1	10	906532



resistance to temp. -15°C setting time 30-35 sec

superstrong
 honey

index	kg	pcs	pcs	5906757
MN-97-994-1	1,00	1	1	906433
MN-97-994-5	5,00	1	1	906488
MN-97-994-B	0,10	1	10	906525



resistance to temp. -5°C setting time 35-40 sec.

transparent

PVC, cables, plastics PVC, cables, plastics ПВХ, кабель, пластмасса

GLUE STICKS FOR GLUE GUNS PRO-T



index	kg	pcs	pcs	5906757
MN-97-995-1	1,00	1	5	906440
MN-97-995-5	5,00	1	1	906501
MN-97-995-B	0,10	1	10	906549



resistance to temp. 0°C setting time 25-30 sec

biały white молочный

GLUE STICKS FOR GLUE GUNS PRO-B



index	kg	pcs	pcs	5906757
MN-97-996-1	1,00	1	1	906457
MN-97-996-5	5,00	1	1	906761
MN-97-996-B	0,10	1	10	906556



resistance to temp. -5°C setting time 30-35 sec.

honey

GLUE STICKS FOR GLUE GUNS ASS



index	kg	pcs	pcs	5906757
MN-97-997-1	1,00	1	1	906464
MN-97-997-5	5,00	1	1	906778
MN-97-997-B	0,10	1	10	906563



resistance to temp. 0°C setting time 8-12 sec.

mleczny milk молочный

GLUE STICKS FOR GLUE GUNS PAC



index	Dedicated to	Capacity	590		
			l/l	pcs	
MN-94-190	DEWALT, KÄRCHER	12,5	1	5	6675329208
MN-94-192	NILFISK Multi	13,5	1	5	1362007315
MN-94-193	DELONGHI, DEXTER, EINHELL, MODECO (MN-94-151)	7,4	1	5	6675192888
MN-94-194	EINHELL, GRAPHITE, PARKSIDE	9,6	1	5	6675192895
MN-94-196	MODECO EXPERT, KÄRCHER	10,5	1	5	6675193243
MN-94-197	KÄRCHER SER. A	3,8	1	5	6675193250
MN-94-198	KÄRCHER, ELECTROLUX, TORNADO	12,5	1	5	6675193281
MN-94-199	KÄRCHER WD 3, AQUA VAC, EINHELL, ROWENTA	25,6	1	12	6675193304
MN-94-200	METABO, BOSCH, KRESS	15,0	1	5	6675193311
MN-94-201	MACALLISTER, MODECO (MN-94-152)	19,3	1	12	6675193335
MN-94-202	MAKITA 440, 445, 448	19,7	1	12	6675201320
MN-94-203	GRAPHITE, MICHELIN	15,0	1	5	1362007483

BAGS FOR VACUUM CLEANERS

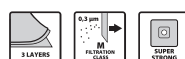

Basic tools are indispensable in every household and workshop. With their help, any DIYer can easily handle the repair of many defects.

BASIC TOOLS

Basic tools are easy to use, making it possible to work quickly and efficiently, let alone effectively and, most importantly, safely. The range of the Modeco Expert basic tools comprises high-quality tools made of good-quality materials and alloy steels. There is something for everyone – from professionals, who provide their services on a large scale, to DIYers. Their main targets include fitters, mechanics, electricians, plasterers, DIYers, roofers, road builders, tile setters, plumbers, joiners, and steel fixers. It is for them that we have designed and developed the Modeco Expert selection of basic tools including screwdrivers, voltage testers, pliers, cutters, pipe spanners, hammers, vices, and clamps.





FLAT SCREWDRIVERS SUPREME



index					5906757
	mm	mm	pcs	pcs	
MN-10-151	3,0	75	6	120	902695
MN-10-152	4,0	75	6	120	902701
MN-10-153	5,0	100	6	90	902718
MN-10-154	5,0	150	6	120	902725
MN-10-157	6,0	100	6	90	902749
MN-10-159	6,0	150	6	90	902756
MN-10-160	8,0	150	6	60	902763



PHILIPS SCREWDRIVERS SUPREME



index					5906757
	mm	mm	pcs	pcs	
MN-10-161	PH0	60	6	120	902770
MN-10-162	PH1	80	6	120	902787
MN-10-163	PH2	38	6	120	902794
MN-10-165	PH2	100	6	90	902800
MN-10-168	PH3	150	6	60	902817



POZIDRIVE SCREWDRIVERS SUPREME



index					5906757
	mm	mm	pcs	pcs	
MN-10-171	PZ0	60	6	120	902824
MN-10-172	PZ1	80	6	120	902831
MN-10-173	PZ2	38	6	120	902848
MN-10-175	PZ2	100	6	90	902855



SCREWDRIVER SET PH 4 PCS SUPREME



index				5906757
	pieces	pcs	pcs	
MN-11-081	4	6	24	903074



	mm	mm		
	⌀	5,0	100	
	⌀	6,0	150	
	⊕	PH1	75	
	⊕	PH2	100	





SCREWDRIVER SET PH PCS SUPREME



index				5906757
	pieces	pcs	pcs	
MN-11-082	6	6	24	903081



	mm	mm		
	⌀	3,0	75	
	⌀	5,0	75	
	⌀	5,0	150	
	⊕	PH0	75	
	⊕	PH1	100	
	⊕	PH2	100	





index						5906757
	mm	mm	mm	pcs	pcs	
MN-13-004	6,0	1,2	100	12	96	119840
MN-13-007	8,0	1,2	150	12	96	267930
MN-13-009	9,0	1,5	200	12	96	271357



FLAT SCREWDRIVERS WITH STRIKING CAPS IMPACT





BASIC TOOLS

index					5906757
	mm	mm	pcs	pcs	
MN-13-014	PH2	100	12	96	267947
MN-13-017	PH3	150	12	96	267954











FLAT SCREWDRIVERS PH2/PH3





index				5906757
	pieces	pcs	pcs	
MN-10-107	13	6	24	013800



















		
	mm	mm
		3,0; 4,0; 5,0; 6,0; 7,0
		PH0; PH1; PH2; PH3
		PZ1; PZ2; PZ3

SCREWDRIVER WITH INTERCHANGEABLE BITS SUPREME



index				5906675
	pieces	pcs	pcs	
MN-10-200	29	6	24	489872



		
	mm	mm
		3; 4; 5; 6; 7
		PH1; PH2; PH3
		PZ1; PZ2
		T15; T20; T25
		1; 2; 3
		5; 6; 7; 8; 9; 10; 11
		3; 4; 5

"T" SCREWDRIVER WITH INTERCHANGEABLE BITS AND SOCKETS



SCREWDRIVER SET 39 PCS



index	📄	📦	📦	5906757
	pieces	pcs	pcs	
MN-14-205	39	6	24	088693

CR-V

	📏	mm	mm
	⌀	3,0; 4,0; 5,0; 6,0	25
	+	PH0; PH1; PH2; PH3	25
	+	PZ0; PZ1; PZ2; PZ3	25
	⌘	T10; T15; T20; T25; T27; T30	25
	●	4, 5, 6	25
	○	4,0; 4,5; 5,0; 5,5; 6,0; 6,5; 7,0; 8,0; 9,0; 10,0; 11,0; 13,0	25

SCREWDRIVER SET 45 PCS



index	📄	📦	📦	5906757
	pieces	pcs	pcs	
MN-14-206	45	6	24	088709

CR-V

	📏	mm	mm
	⌀	3,0; 4,0; 5,0; 6,0	25
	+	PH0x2; PH1x2; PH2x2; PH3	25
	+	PZ0x2; PZ1x2; PZ2x2; PZ3	25
	⌘	T10; T15; T20; T25; T27; T30; T40	25
	●	4, 5, 6	25
	○	4,0; 4,5; 5,0; 5,5; 6,0; 6,5; 7,0; 8,0; 9,0; 10,0; 11,0; 13,0	25

	📏	cal/inch/дюйм
	○	1/2"

SCREWDRIVER SET 67 PCS



index	📄	📦	📦	5906757
	pieces	pcs	pcs	
MN-14-207	67	6	24	088716

CR-V

	📏	mm	mm
	⌀	3,0 x2; 4,0 x2; 5,0 x2; 6,0 x2; 7,0 x2	25
	+	PH0 x2; PH1 x2; PH2 x2; PH3 x2	25
	+	PZ0 x2; PZ1 x2; PZ2 x2; PZ3 x2	25
	⌘	T10 x2; T15 x2; T20 x2; T25 x2; T27 x2; T30 x2; T40 x2	25
	⌘	T10 x2; T15 x2; T20 x2; T25 x2; T27 x2; T30 x2	25
	●	1, 2, 3	25

TOOLS FOR ELECTRICIANS

The work performed by electricians involves occupational hazards associated with the maintenance of indoor and outdoor electrical equipment and systems as well as with building construction.

What we can do to increase the safety and comfort of their work is to provide suitable products catering to the needs of this professional group. The Modeco Expert electrician's tools are characterised by high durability, human engineering properties that improve work quality and comfort, and multi-functionality, which translates into fewer individual tools in an electrician's toolbox.

The Modeco Expert electrician's tools featuring 1000V insulation ensure efficient and safe work. In this product group, both professional electricians and DIYers will find products that meet their specific needs. Additionally, the Modeco Expert group has created a series of tools that allow you to perform additional wire working activities. These include a specialised high-precision telephone and network terminal crimping tool, an automatic wire stripper dedicated to cables of various diameters, and a cable crimping tool featuring a high-precision automatic press.

▶ **3 tools in one** - cutting, crimping terminals and stripping with processing the cable to a specific length

▶ **Jaws for crimping** cable lugs in the range of 10-22 AWG (0.5-6 mm²) and a diameter of 7-8 mm





◀ **Automatic adjustment** to the cable diameter protects it from damage and increases work efficiency

◀ **The wire cutter** located in the handle guarantees the cutting of Cu and Al conductors with a maximum cross-section of 6 mm²



VDE INSULATED SCREWDRIVERS - SL







index						5906757
	mm	mm	mm	pcs	pcs	
MN-10-551	3,5	0,6	75	12	240	268715
MN-10-552	4,0	0,8	100	12	240	268722
MN-10-553	5,5	1,0	125	12	144	268739
MN-10-554	6,5	1,2	150	12	144	268753



VDE INSULATED SCREWDRIVERS - PH



index						5906757
	mm		mm	pcs	pcs	
MN-10-561	PH0		75	12	240	268760
MN-10-562	PH1		100	12	240	268777
MN-10-563	PH2		100	12	144	268784

















VDE INSULATED SCREWDRIVER SET PH 6 PCS







index			5906757
	pieces	pcs	
MN-11-070	6	12	136298



		
	mm	mm
		75
		100
		125
		100
		100
		100

VDE INSULATED SCREWDRIVERS - SL







index						5906675
	mm	mm	mm	pcs	pcs	
MN-10-570	2,5	0,6	75	12	144	489698
MN-10-571	4,0	0,8	100	12	144	489704
MN-10-572	5,5	1,0	125	12	144	489711
MN-10-573	6,5	1,2	150	12	144	489728



VDE INSULATED SCREWDRIVERS - PH



index						5906675
	mm		mm	pcs	pcs	
MN-10-580	PH0		75	12	144	489735
MN-10-581	PH1		80	12	144	489742
MN-10-582	PH2		100	12	144	489759







index					5906757
	mm	mm	pcs	pcs	
MN-17-050	3,0	140	50	100	128576



VEHICLE CIRCUIT TESTER 6-24V







index					5906675
	mm	mm	pcs	pcs	
MN-17-140	3,5	140	20	500	026824



VOLTAGE DETECTOR 100-500V





index					5906675
	mm	mm	pcs	pcs	
MN-17-190	3,5	190	10	400	026831



VOLTAGE DETECTOR 100-250V







index				5906757
	V/B	pcs	pcs	
MN-17-200	70-250	12	240	121133



AUTOMATIC VOLTAGE TESTER 5in1 70-250 V



index					5906757
	mm	mm	pcs	pcs	
MN-17-240	3,0	140	30	480	000490
MN-17-240/1	3,0	140	30	480	000506
MN-17-290	3,5	190	30	480	5906675026831
MN-17-290/1	3,5	190	30	480	000520



VOLTAGE DETECTOR 100-250V



VOLTAGE DETECTOR



NEW

index	mm	pcs	pcs	5906757
MN-17-300	3,0	10	240	001985



VOLTAGE DETECTOR



NEW

index	mm	pcs	pcs	5906757
MN-17-302	3,0	10	200	002005

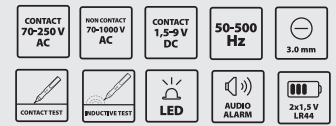

VOLTAGE DETECTOR



NEW

index	mm	pcs	pcs	5906757
MN-17-305	3,0	12	96	002012



VOLTAGE DETECTOR



NEW

index	mm	pcs	pcs	5906757
MN-17-307	3,0	12	96	002036





CONTROL CABINET KEY 10 ENDS



index	pieces	pcs	pcs	5906675
MN-14-210	3	50	100	489513





index				5906675
	mm	pcs	pcs	
MN-20-080	160	6	60	489766
MN-20-081	180	6	60	489773
MN-20-082	200	6	60	489780



ALL-PURPOSE INSULATED PLIERS VDE





index				5906675
	mm	pcs	pcs	
MN-20-092	180	6	60	489810



SIDE-CUTTING INSULATED PLIERS VDE





index				5906675
	mm	pcs	pcs	
MN-20-098	160	6	60	489889



SIDE-CUTTING INSULATED PLIERS VDE





index				5906675
	mm	pcs	pcs	
MN-20-094	160	6	60	489841



SIDE-CUTTING INSULATED PLIERS VDE



index				5906675
	mm	pcs	pcs	
MN-20-096	160	6	60	489858





SIDE-CUTTING INSULATED PLIERS VDE



WIRE STRIPPING INSULATED PLIERS VDE





index				5906675
	mm	pcs	pcs	
MN-23-057	160	6	60	489865



STRAIGHT-NOSE INSULATED PLIERS VDE





index				5906675
	mm	pcs	pcs	
MN-20-086	160	6	60	489797
MN-20-087	200	6	60	489803



CURVED-NOSE INSULATED PLIERS VDE





index				5906675
	mm	pcs	pcs	
MN-20-088	160	6	60	489827
MN-20-089	200	6	60	489834



PLUMBERS INSULATED PLIERS VDE







index				5906757
	mm	pcs	pcs	
MN-20-651	250	6	36	902381







INSULATED ELECTRICIAN'S KNIFE VDE



index					5906675
	mm	mm	pcs	pcs	
MN-63-055	180	45	6	60	489575
MN-63-056	190	50	6	60	489582







index					5906675
	mm	mm ²	pcs	pcs	
MN-23-060	180	0,2-6,0	10	60	489520



AUTOMATIC WIRE STRIPPER







index					5906675
	mm	mm ²	pcs	pcs	
MN-23-062	170	1,2-3,2	8	48	489537



AUTOMATIC WIRE STRIPPER



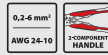

index					5906675
	mm	mm ²	pcs	pcs	
MN-23-064	205	0,15-6	10	60	489544



AUTOMATIC WIRE STRIPPER







index				5906757
	mm ²	pcs	pcs	
MN-23-079	0,5-6,0	10	50	268029



AUTOMATIC WIRE STRIPPER



index					5906675
	mm	mm ²	pcs	pcs	
MN-23-066	125	0,34-6	1	120	489551







WIRE STRIPPING PLIERS



WIRE STRIPPER







index	 L				5906675
	mm	mm ²	pcs	pcs	
MN-23-068	190	8-28	1	100	489568



CABLE SHEARS







index					5906675
	mm	mm	pcs	pcs	
MN-26-020	250	do 32	10	60	489650



CABLE SHEARS



index					5906675
	mm	mm	pcs	pcs	
MN-26-023	185	do 13	12	72	489667



CABLE SHEARS







index					5906675
	mm	mm	pcs	pcs	
MN-26-027	250	do 13	6	36	489681







WIRE AND WIRE ROPE CUTTER



index					5906675
	mm	mm	pcs	pcs	
MN-26-025	190	1,2/4,0	10	60	489674





index					5906757
	mm	mm	pcs	pcs	
MN-20-100	200	15	6	60	001978





MULTIFUNCTIONAL PLIERS 6in1



index					5906675
	mm	type	pcs	pcs	
MN-20-180	195	8P, 6P, 4P	8	48	489599









CRIMPING PLIERS FOR MODULAR CONNECTORS



index					5906675
	mm	mm ²	pcs	pcs	
MN-20-184	175	0,25-6	6	36	489612

CRIMPING PLIERS







index					5906675
	mm	mm ²	pcs	pcs	
MN-20-187	225	0,5-6	10	30	489636





CRIMPING PLIERS



index					5906675
	mm	mm ²	pcs	pcs	
MN-20-189	220	0,5-16	12	24	489643









CRIMPING PLIERS



CRIMPING PLIERS FOR END SLEEVES





index					5906757
	mm	mm ²	pcs	pcs	
MN-20-191	140	0,25-2,5	20	80	002067
MN-20-192	140	1,5-6	20	80	002074



ALL-PURPOSE PLIERS FRIENDLY GRIP





index				5906757
	mm	pcs	pcs	
MN-20-026	160	6	60	156982
MN-20-027	180	6	48	156999
MN-20-028	200	6	48	157002



SIDE-CUTTING PLIERS FRIENDLY GRIP





index				5906757
	mm	pcs	pcs	
MN-20-126	160	6	60	157019
MN-20-127	180	6	60	157026



STRAIGHT-NOSE TELEPHONE PLIERS FRIENDLY GRIP





index				5906757
	mm	pcs	pcs	
MN-20-226	160	6	60	157033





CURVED-NOSE TELEPHONE PLIERS FRIENDLY GRIP

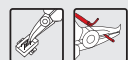

index				5906757
	mm	pcs	pcs	
MN-20-326	160	6	60	157057



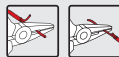

index				5906757
	mm	pcs	pcs	
MN-20-526	160	6	60	157040



FLAT TELEPHONE PLIERS FRIENDLY GRIP







index				5906757
	mm	pcs	pcs	
MN-20-620	250	6	48	165908



PLUMBER'S PLIERS FRIENDLY GRIP







index					5906757
	mm	mm	pcs	pcs	
MN-20-660	250	35	6	60	002432



PLUMBER'S PLIERS AUTOMATIC



NEW

index					5906757
	mm	mm	pcs	pcs	
MN-20-706	150	8-30	6	60	140714
MN-20-708	175	30-60	6	60	121867
MN-20-710	225	60-100	6	30	263499





STRAIGHT EXTERNAL CIRCIP PLIERS



BENT EXTERNAL CIRCLIP PLIERS





index		∅			5906757
	mm	mm	pcs	pcs	
MN-20-716	150	8-30	6	60	140721
MN-20-718	175	30-60	6	60	121881
MN-20-720	225	60-100	6	30	263505



STRAIGHT INTERNAL CIRCLIP PLIERS





index		∅			5906757
	mm	mm	pcs	pcs	
MN-20-726	150	8-30	6	60	140738
MN-20-728	175	30-60	6	60	121898
MN-20-730	225	60-100	6	30	263512



BENT INTERNAL CIRCLIP PLIERS





index		∅			5906757
	mm	mm	pcs	pcs	
MN-20-736	150	8-30	6	60	140745
MN-20-738	175	30-60	6	60	121874
MN-20-740	225	60-100	6	60	263529





ALL-PURPOSE ELECTRICAL PLIERS



index				5906757
	mm	pcs	pcs	
MN-20-005	115	6	120	126619





index				5906757
	mm	pcs	pcs	
MN-20-105	115	6	120	126626



SIDE-CUTTING ELECTRICAL PLIERS





BASIC TOOLS

index				5906757
	mm	pcs	pcs	
MN-20-165	115	6	120	140554



END-CUTTING ELECTRICAL PLIERS



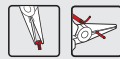

index				5906757
	mm	pcs	pcs	
MN-20-205	130	6	120	140561



STRAIGHT-NOSE TELEPHONE PLIERS



index				5906757
	mm	pcs	pcs	
MN-20-265	150	6	120	140585





STRAIGHT NEEDLE-NOSE TELEPHONE PLIERS



CURVED-NOSE TELEPHONE PLIERS



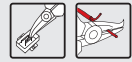

index				5906757
	mm	pcs	pcs	
MN-20-305	130	6	120	140578







FLAT-NOSE ELECTRONIC PLIERS



index				5906757
	mm	pcs	pcs	
MN-20-505	130	6	120	147263

SIDE-CUTTING PLIERS WITH ARTICULATED JOINT







index					5906757
	mm	mm	pcs	pcs	
MN-20-146	165	1,8	6	36	268654
MN-20-147	190	2,0	6	36	268661

CR-V

PLUMBER'S PLIERS







index					5906757
	mm	mm	pcs	pcs	
MN-20-607	180	30	6	72	273122
MN-20-610	250	35	6	60	133556
MN-20-612	300	40	6	48	273115





CR-V

SIDE-CUTTING PLIERS



index					5906675
	mm	mm	pcs	pcs	
MN-26-076	150	1,5	1	6	349657
MN-26-077	175	2,0	1	6	349664







index					5906757
	mm	mm	pcs	pcs	
MN-26-016	160	1,5	6	48	245266
MN-26-017	180	2,0	6	48	245273
MN-26-018	200	2,5	6	36	245280

CR-V

PINCERS





index					5906757
	mm	mm	pcs	pcs	
MN-26-066	160	2,0	6	48	245761
MN-26-067	180	2,5	6	36	245778

CR-V

END-CUTTING PINCERS





index				5906757
	mm	pcs	pcs	
MN-26-120	250	6	60	245303
MN-26-121	275	6	36	245310
MN-26-122	300	6	36	245327
MN-26-123	330	6	36	905559

CR-V

TOWER PINCERS





index				5906757
	mm	pcs	pcs	
MN-26-218	190	6	48	267343

CR-V



TILE CUTTING PLIERS



index				5906757
	mm	pcs	pcs	
MN-26-140	250	6	24	002081
MN-26-141	250	6	24	002098
MN-26-142	250	6	24	002104





ROOFING PLIERS 250 MM



MORSE' LOCK GRIP PLIERS





index		Ø max			5906757
	mm	mm	pcs	pcs	
MN-22-008	185	28	6	60	269255
MN-22-011	225	38	6	60	045156



MORSE' LOCK GRIP PLIERS







index		Ø max			5906757
	mm	mm	pcs	pcs	
MN-22-012	215	40	6	48	906648







MORSE' LOCK GRIP PLIERS



index						5906757
	mm	mm	mm	pcs	pcs	
MN-22-014	215	60	65	6	60	906655

MORSE' LOCK GRIP PLIERS







index						5906757
	mm	mm	mm	pcs	pcs	
MN-22-018	230	68	75	6	24	906679







PIPE HOOK WRENCH



NEW

index					5906757
	mm	mm	pcs	pcs	
MN-25-200	300	16-38	6	24	002364





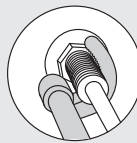

index					5906757
	mm	mm	pcs	pcs	
MN-25-220	240	10-32	1	20	002357



SANITARY FITTINGS WRENCH



NEW

index						5906757
	mm	cal/inch/дюйм	mm	pcs	pcs	
MN-25-101	300	1	38	1	36	268685
MN-25-102	410	1½	48	1	18	268692
MN-25-103	535	2	60	1	12	119895





CR-V

90-DEGREE ADJUSTABLE PIPE WRENCH



145-S ADJUSTABLE PIPE WRENCH







index						5906757
	mm	cal/inch/дюйм	mm	pcs	pcs	
MN-25-110	240	½	45	1	48	268708
MN-25-111	315	1	60	1	36	140066
MN-25-112	425	1½	75	1	18	126428
MN-25-113	555	2	90	1	12	140073
MN-25-115	655	3	140	1	5	159808

CR-V

STILLSON ADJUSTABLE PIPE WRENCH





index						5906757
	mm	cal/inch/дюйм	mm	pcs	pcs	
MN-25-410	250	1¾	54	1	24	134058
MN-25-412	300	2	60	1	24	134065
MN-25-414	350	2	60	1	24	134089
MN-25-418	450	2½	76	1	12	134072
MN-25-424	600	3½	102	1	8	157224



DEBURRER



NEW

index				5906757
	mm	pcs	pcs	
MN-62-590	3-40	6	48	002418



BASIC TOOLS

DEBURRER



NEW

index			5906675
	pcs	pcs	
MN-62-592	25	100	527680



COPPER PIPE BRUSH



NEW

index				5906757
	mm	pcs	pcs	
MN-69-200	15, 22	25	50	002388

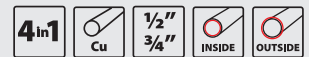

PIPE BENDER 15/22 MM



NEW

Available 09.2024

index				590667
	mm	pcs	pcs	
MN-62-600	15, 22	1	4	5530024



PIPE BENDER 6/8/10 MM



NEW

Available 09.2024

index				590667
	mm	pcs	pcs	
MN-62-601	6,8,10	1	20	5554488



HAMMERS



The most essential and popular product that comes in handy in most home and workshop repair works is a hammer.

Depending on the application, the best choice appears to be either a hammer with a metal face and a handle made from one piece of forged induction-hardened steel (monoblock) or a hammer with a fiberglass handle. These characteristics guarantee lifetime durability and vibration dampening that significantly increases working comfort. With safety and convenience of use in mind, we have equipped our hammers with durable rubber-coated handles ensuring anti-slip properties, which guarantees secure grip, and a hammer face featuring a magnet which makes it easier to hold the nail being driven.



HAMMER FACE AND HANDLE ◀
MADE FROM ONE PIECE of
induction-hardened material for
supreme product durability

WEDGE-SHAPED INDENTATION ◀
BETWEEN HAMMER CLAWS for
easier nail pulling



▶ **RUBBER-COATED AND
ERGONOMICALLY SHAPED
HANDLE** with anti-slip
properties for secure grip

▶ **MAGNETIC HAMMER FACE,**
making it easier to hold the nail
being driven



CARPENTER'S HAMMER SUPREME



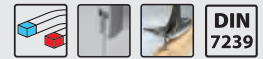

index				5906757
	kg	pcs	pcs	
MN-32-001	0,6	6	24	028071



CARPENTER'S HAMMER MONOBLOCK



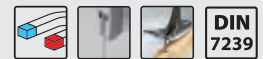

index				5906757
	kg	pcs	pcs	
MN-32-008	0,6	6	24	164789





MASONRY HAMMER - BERLIN PATTERN (WIDE) MONOBLOCK



index				5906757
	kg	pcs	pcs	
MN-32-013	0,6	6	24	268166



MASONRY HAMMER - RHINE PATTERN (NARROW) MONOBLOCK





index				5906757
	kg	pcs	pcs	
MN-32-018	0,6	6	24	268173

CARPENTER'S HAMMER FIBERGLASS





index				5906757
	kg	pcs	pcs	
MN-32-007	0,6	6	24	140141



index	 kg	 pcs	 pcs	5906757
MN-32-012	0,6	6	24	272200



MASONRY HAMMER - BERLIN PATTERN (WIDE) FIBERGLASS



index	 kg	 pcs	 pcs	5906757
MN-32-017	0,6	6	24	272217



MASONRY HAMMER - RHINE PATTERN (NARROW) FIBERGLASS



index	 kg	 pcs	 pcs	5906757
MN-32-022	0,45	6	24	272224



CARPENTER'S HAMMER – AMERICAN PATTERN FIBERGLASS



index	 kg	 pcs	 pcs	5906757
MN-30-603	0,3	6	48	001831
MN-30-605	0,5	6	36	001848
MN-30-608	0,8	6	24	001855
MN-30-610	1,0	6	24	001862
MN-30-615	1,5	6	12	001879
MN-30-620	2,0	6	12	001886

HAMMERS FIBERGLASS



index	 kg	 pcs	 pcs	5906757
MN-30-402	0,2	6	60	273191
MN-30-403	0,3	6	48	273207
MN-30-404	0,4	6	36	273214
MN-30-405	0,5	6	18	273221
MN-30-408	0,8	6	12	273238
MN-30-410	1,0	6	12	273245
MN-30-415	1,5	6	12	273252
MN-30-420	2,0	6	12	273269

HAMMERS



RUBBER Mallet



index				5906675
	kg	pcs	pcs	
MN-31-212	0,35	12	36	024066
MN-31-216	0,45	6	24	024097
MN-31-224	0,68	6	24	024103
MN-31-232	0,90	6	24	024110

MASON'S HAMMER FIBERGLASS



index				5906675
	kg	pcs	pcs	
MN-32-103	1,5	6	12	028101

RUBBER PROTECTION



index				5906675
	kg	pcs	pcs	
MN-33-005	1,5	20	20	085937



AXES WITH WEDGES



index		L			5906757
	kg	mm	pcs	pcs	
MN-64-027	1,2	600	6	24	152434
MN-64-029	1,2	800	6	24	152441



FORGED AXES



index		L			5906757
	kg	mm	pcs	pcs	
MN-64-090	0,6	360	1	5	909243
MN-64-092	1,0	500	1	5	909250
MN-64-094	1,25	700	1	5	909267
MN-64-096	1,5	700	1	5	909274







AXES



index				5906757
	kg	pcs	pcs	
MN-64-206	0,60	6	24	152434
MN-64-208	0,80	6	24	152441
MN-64-210	1,00	6	24	152458
MN-64-212	1,25	6	12	155510
MN-64-215	1,50	6	12	268241
MN-64-218	1,80	6	12	268234







index					5906757
	kg	mm	pcs	pcs	
MN-35-214	7,0	100	1	2	274983
MN-35-215	10,5	125	1	1	274990
MN-35-216	16,5	150	1	1	275003



FITTER'S SWIVEL-BASE VICES





index					5906757
	kg	mm	pcs	pcs	
MN-35-400	7,2	10-115	1	2	274983

PIPE CLAMPING VICE



NEW



Available 09.2024

index	L	A			5906757
	mm	mm	pcs	pcs	
MN-37-200	150	50	1	50	246164
MN-37-201	200	50	1	50	147331
MN-37-230	300	80	1	30	147348
MN-37-243	300	120	1	20	147362
MN-37-245	500	120	1	10	147379
MN-37-248	800	120	1	10	150973
MN-37-250	1000	120	1	10	150980
MN-37-255	1500	120	1	6	245587

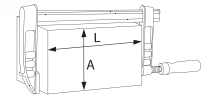
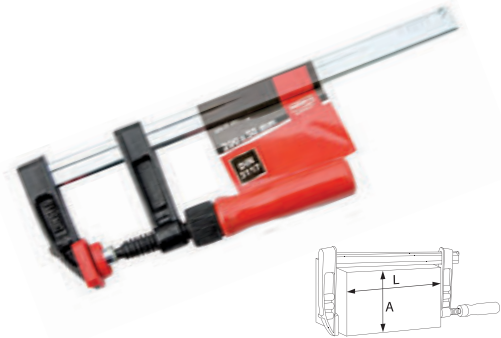

BAR CLAMPS







index	L	A			5906750
	mm	mm	pcs	pcs	
MN-37-260	150	50	1	20	19987
MN-37-262	200	50	1	20	19994
MN-37-263	300	80	1	10	20006
MN-37-264	300	120	1	10	20013
MN-37-265	500	120	1	10	20020
MN-37-266	800	120	1	6	20037
MN-37-270	1000	120	1	6	20044

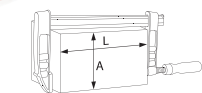
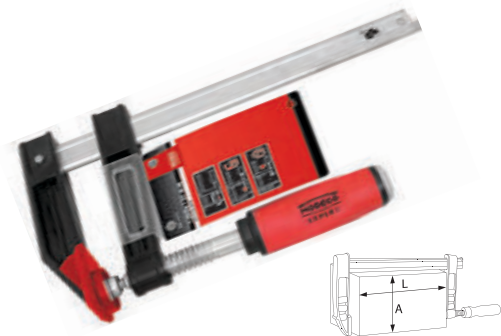

BAR CLAMPS STRONG GRIP



index	L					5906675
	mm	mm	mm	pcs	pcs	
MN-37-353	80	30	35	1	100	426532
MN-37-354	100	40	45	1	40	426549
MN-37-356	170	60	65	1	20	426556
MN-37-359	205	80	85	1	20	426563

SPRING CLAMP



CONNECTING TOOLS

The Modeco Expert branded connecting tools include, above all, staplers, riveters and crimping tools for drywall systems. They are appreciated for their high quality, durability, and convenience in use.

The riveters are intended for joining two independent pieces, such as elements of brackets, shields, or enclosures, by means of rivets and rivet nuts made of steel, stainless steel, aluminium, or copper. They come in handy wherever DIYers, carpenters, installers, and carpenters perform their job.

Staplers are tools used to join materials by puncturing them, and these materials include wood, fabric, paper, or foil. Special clips or nails of different sizes and types are used for this purpose. Their main application is professional upholstery work, but they also come in handy in household and decoration activities.





STAPLE GUNS

One of the most highly valued items in the Modeco Expert portfolio of connecting tools is our metal hand stapler, suitable for a wide selection of pins ranging in sizes from 4 to 14mm, making it possible to join materials of various thicknesses.

It proves most useful at workshops of upholsterers, joiners, roofers, or DIYers. It is typically used for quick joining of different materials, such as wood, fabric, paper, and foil. It features a stepless impact force control function, which makes it possible to adjust the pin driving force depending on its length and material hardness. Another advantage of the stapler is the content viewing capability that allows you to keep track of the number of pins left in the tool magazine without having to stop working.

STEPLESS IMPACT FORCE CONTROL allowing you to adjust the pin driving force depending on the pin length and material hardness

▶ **HANDLE WITH ANTI-SLIP COATING** ensures comfortable and safe use

▶ **STEEL BODY** ensures long tool life



▶ **VIEWING THE CONTENT OF STAPLES** allows you to control the amount of staples in the magazine without having to stop working

index	M53			5906757
	mm	pcs	pcs	
MN-45-109	4-14	10	40	000544
MN-45-110	4-14	10	40	097698



HAND STAPLE GUN

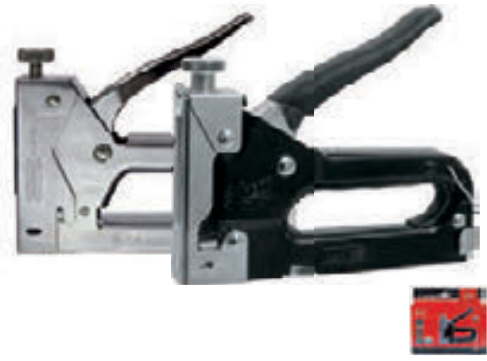

index	M11	M36	M300			5906757
	mm	mm	pcs	pcs	pcs	
MN-45-120	4-14	10-14	14	6	24	272231



HAND STAPLE GUN 4 IN 1



index			5906757
	pcs	pcs	
MN-45-100	20	120	907249

STAPLE REMOVER



index	M53			5906757
	mm	pcs	pcs	
MN-46-106	6	10	10	162457
MN-46-108	8	10	10	162464
MN-46-110	10	10	10	162471
MN-46-112	12	10	10	162488
MN-46-114	14	10	10	162495



STAPLES



index	M11			5906757
	mm	pcs	pcs	
MN-46-146	6	1	10	272781
MN-46-148	8	1	10	272798
MN-46-150	10	1	10	272804
MN-46-152	12	1	10	272811
MN-46-154	14	1	10	272828



STAPLES

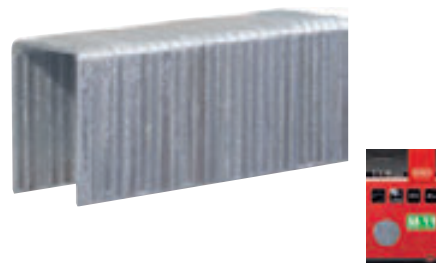

RIGHT ANGLE RIVETER



index				5906757
	mm	pcs	pcs	
MN-40-006	250	12	24	134348



RIGHT ANGLE RIVETER



index				5906675
	mm	pcs	pcs	
MN-40-017	200	5	30	023908



RIGHT ANGLE RIVETER MAXX



index				5906757
	mm	pcs	pcs	
MN-40-007	250	12	24	271456



RIGHT ANGLE RIVETER



index				5906675
	mm	pcs	pcs	
MN-40-018	240	6	24	023915





RIVET NUT TOOL M3-M6



index				5906757
	mm	pcs	pcs	
MN-40-110	250	1	16	907300





index				5906757
	mm	pcs	pcs	
MN-40-020	540	1	12	268494



LONG ARM RIVETER



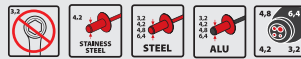

index				5906675
	mm	pcs	pcs	
MN-40-023	325	1	12	023939



DOUBLE HAND RIVET GUN



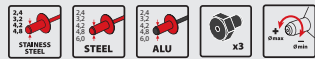

index				5906757
	mm	pcs	pcs	
MN-40-025	790	6	12	268289



LAZY TONG RIVETER





index				5906757
	mm	pcs	pcs	
MN-40-305	250	6	24	901674



BENDER FOR DRYWALLSECTIONS



index				5906757
	mm	pcs	pcs	
MN-40-310	340	6	24	901681



BENDER FOR DRYWALLSECTIONS



Mechanical tools and automotive products are essential in every garage and workshop. They are typically used by DIYers, but also by professionals in car mechanics, plumbing, and installation.

MECHANICAL TOOLS AND AUTOMOTIVE ARTICLES

It is extremely important that these tools are reliable, made of durable top-quality materials, and ergonomic. And these are precisely the tools delivered by Modeco Expert. The brand's offering comprises adjustable spanners, open-ended spanners, open-ended/box (combination) spanners, open-ended/socket spanners, torque spanners, ratchet spanners, adapters and sockets, intended for all kinds of mechanical and installation works. Users can either customise their tool sets themselves by choosing spanners of specific sizes or use professional ready-made sets. Whatever their choice may be, the products they pick will make their work efficient, satisfying, easy, and faster.





WRENCHES

The most common spanners used, for example, in workshops are combination spanners. They are designed for tightening and loosening of hexagonal bolts and nuts.

The Modeco Expert brand's flagship product is an entire series of combination spanners. Made of high-grade chromium-vanadium steel, they provide long service life and durability. The products feature the MAXXDRIVE system ensuring safe transfer of maximum torque to the bolt or nut. This provides for secure grip of the fastening pieces being screwed in or out. Some additional user advantages are that the products are covered by a 5-year manufacturer's warranty, and that they are manufactured in line with the DIN 3113 standard, which guarantees the high quality of the product make.

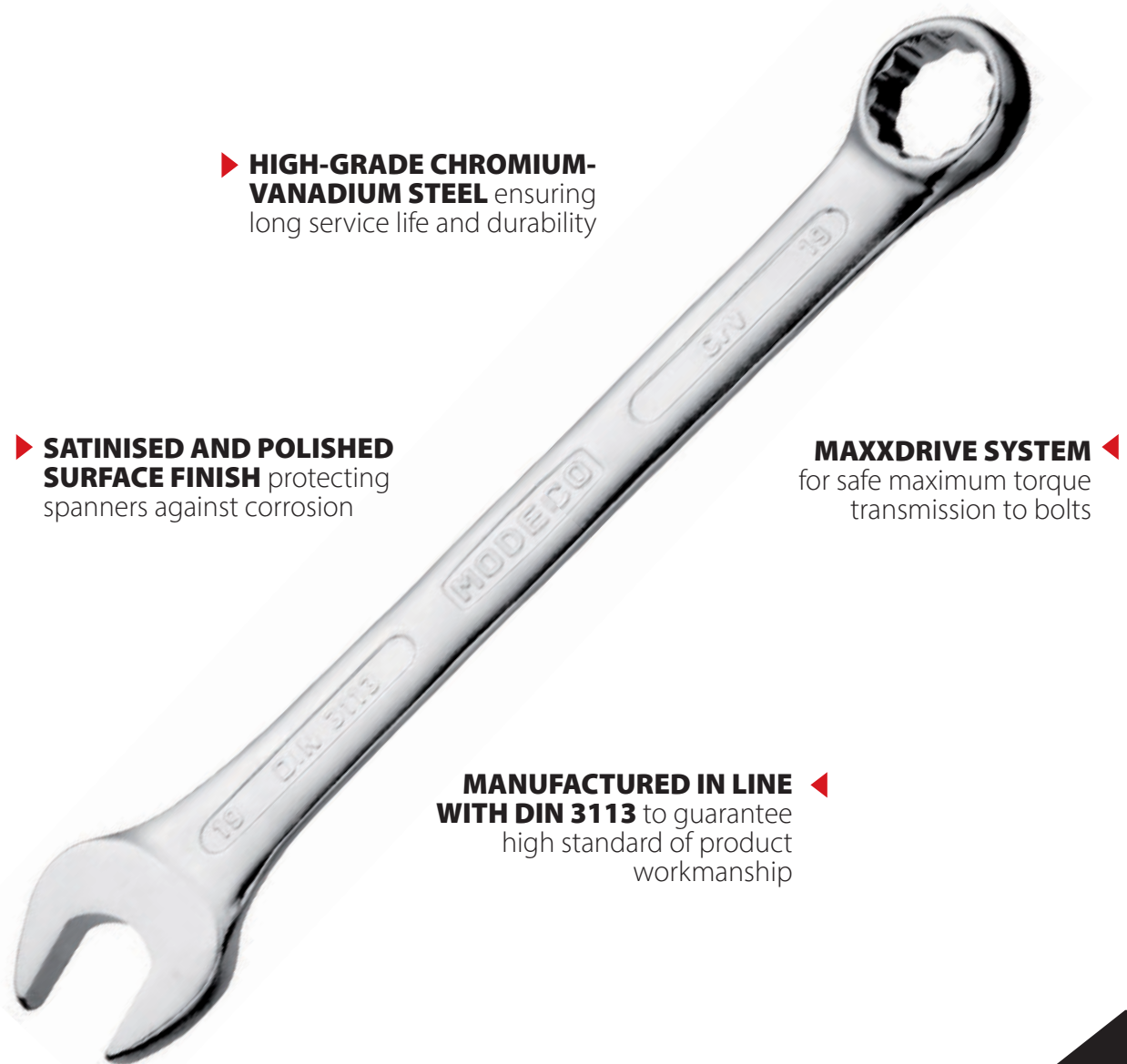





▶ **HIGH-GRADE CHROMIUM-VANADIUM STEEL** ensuring long service life and durability

▶ **SATINISED AND POLISHED SURFACE FINISH** protecting spanners against corrosion

MAXXDRIVE SYSTEM ◀ for safe maximum torque transmission to bolts

MANUFACTURED IN LINE WITH DIN 3113 ◀ to guarantee high standard of product workmanship

index						5906757
	mm	mm	mm	pcs	pcs	
MN-50-413	8	10	140	12	288	163331
MN-50-422	10	13	170	12	288	267534
MN-50-428	13	17	200	12	180	163348
MN-50-440	17	19	220	12	96	163355
MN-50-449	19	22	230	12	72	163362
MN-50-453	22	24	245	6	72	267541
MN-50-456	24	27	265	6	48	163379
MN-50-458	27	30	295	6	24	267558
MN-50-462	30	32	295	6	36	163386



CR-V

DIN 3110

OPEN-END WRENCHES



MECHANICAL TOOL



index				5906757
	pieces	sets	sets	
MN-50-236	6	6	24	163393

CR-V

DIN 3110

6-PIECE OPEN-END WRENCH SET



		
mm	mm	mm
6	7	120
8	9	140
10	13	170
12	13	170
14	15	185
16	17	200



index				5906757
	pieces	sets	sets	
MN-50-238	8	6	24	163409

CR-V

DIN 3110

8-PIECE OPEN-END WRENCH SET



		
mm	mm	mm
7	6	120
9	8	140
13	10	170
13	12	170
15	14	185
17	16	200
19	18	215
22	20	230



index				5906757
	pieces	sets	sets	
MN-50-240	10	6	12	163416

CR-V

DIN 3110





10-PIECE OPEN-END WRENCH SET 6-32 MM



		
mm	mm	mm
7	6	120
9	8	140
11	10	155
13	12	170
15	14	185
17	16	200
19	18	215
22	20	230
27	24	260
32	30	295

OPEN-END BOX WRENCHES MAXXDRIVE





index					5906757
	mm	mm	pcs	pcs	
MN-51-406	6	100	12	288	904996
MN-51-407	7	110	12	288	904989
MN-51-408	8	115	12	288	163423
MN-51-409	9	125	12	240	249479
MN-51-410	10	135	12	288	163430
MN-51-411	11	145	12	72	163447
MN-51-412	12	155	12	288	163454
MN-51-413	13	165	12	288	163461
MN-51-414	14	175	12	144	163478
MN-51-415	15	185	12	144	249486
MN-51-416	16	195	12	144	249493
MN-51-417	17	210	12	144	163485
MN-51-418	18	220	12	96	249509
MN-51-419	19	230	12	96	163492
MN-51-421	21	240	6	96	249516
MN-51-422	22	250	6	96	163508
MN-51-424	24	270	6	72	163515
MN-51-427	27	300	6	48	163522
MN-51-430	30	330	6	36	163539
MN-51-432	32	350	6	36	163546





6-PIECE OPEN-END BOX WRENCH SET MAXXDRIVE 8-17 MM





index				5906757
	pieces	sets	sets	
MN-51-236	6	6	24	163553



	
mm	mm
8	115
10	135
12	155
13	165
14	175
17	210

8-PIECE OPEN-END BOX WRENCH SET MAXXDRIVE 8-19 MM





index				5906757
	pieces	sets	sets	
MN-51-238	8	6	24	163560







	
mm	mm
8	115
9	125
10	135
12	155
13	165
14	175
17	210
19	230

12-PIECE OPEN-END BOX WRENCH SET MAXXDRIVE 6-22 MM



index				5906757
	pieces	sets	sets	
MN-51-242	12	6	18	163577



			
mm	mm	mm	mm
6	100	12	155
7	110	13	165
8	115	14	175
9	125	17	210
10	135	19	230
11	145	22	250

index	pieces	sets	sets	5906757
MN-51-250	20	1	6	163584



mm		mm		mm		mm	
6	100	17	210	23	260	24	270
7	110	18	220	25	280	26	290
8	115	19	230	27	300	28	310
9	125	21	240	30	330	32	350
10	135	22	250				
11	145	24	270				
12	155	27	300				
13	165	30	330				
14	175						
15	185						
16	195						

20-PIECE OPEN-END BOX WRENCH SET MAXXDRIVE 6-32 MM



MECHANICAL TOOL

index	pieces	sets	sets	5906675
MN-51-255	25	1	5	327990



mm		mm		mm		mm	
6	100	15	185	23	260	24	270
7	110	16	195	24	270	25	280
8	115	17	210	26	290	27	300
9	125	18	220	28	310	30	330
10	135	19	230	32	350		
11	145	20	235				
12	155	21	240				
13	165	22	250				
14	175						

25-PIECE OPEN-END BOX WRENCH SET MAXXDRIVE 6-32 MM



index	mm	mm	pcs	pcs	5906757
MN-59-608	8	135	10	300	909816
MN-59-609	9	154	10	200	909823
MN-59-610	10	154	10	200	909830
MN-59-611	11	167	10	200	909847
MN-59-612	12	178	10	180	909854
MN-59-613	13	178	10	180	909861
MN-59-614	14	192	10	90	909878
MN-59-615	15	207	10	120	909885
MN-59-616	16	207	10	100	909892
MN-59-617	17	222	10	100	909908
MN-59-618	18	222	10	100	909915
MN-59-619	19	238	10	60	909922



COMBINATION RATCHET WRENCHES SPEED DRIVE



index	mm	mm	pcs	pcs	5906757
MN-59-710	10	154	10	200	909953
MN-59-713	13	179	10	200	909984
MN-59-717	17	223	10	60	910027
MN-59-719	19	242	10	60	910041



COMBINATION RATCHET WRENCHES WITH PIVOT HEAD SPEED DRIVE



**7-PIECE COMBINATION RATCHET WRENCHES SET
8-19 MM**



index	pieces	sets	sets	5906675
MN-59-657	7	6	24	431024

mm	mm
8	135
10	154
11	167
13	178
15	207
17	222
19	238



**7-PIECE COMBINATION RATCHET WRENCHES SET
8-19 MM**



index	pieces	sets	sets	5906675
MN-59-757	7	6	24	431024

mm	mm
8	142
10	160
11	173
13	193
15	210
17	230
19	248



FLEX HANDLE 1/2" 375 MM



index	inch	mm	pcs	pcs	5906757
MN-55-557	1/2	375	6	24	270961







EXTENSIONS FOR SOCKETS 1/2"



index	inch	mm	pcs	pcs	5906757
MN-55-551	1/2	125	1	100	122345
MN-55-552	1/2	250	1	50	122352







index					5906757
	inch	mm	pcs	pcs	
MN-55-555	1/2	250	1	50	121584



T HANDLE FOR SOCKETS 1/2"







index					5906757
	inch	mm	pcs	pcs	
MN-56-010	1/2	570	1	10	097513



DYNAMOMETRIC WRENCH 1/2"







index					5906757
	inch	mm	pcs	pcs	
MN-55-507	1/4	160	25	100	270947
MN-55-517	1/2	250	10	30	146211



RATCHET WRENCH FOR SOCKETS 1/4", 1/2"







index					5906757
	inch	mm	pcs	pcs	
MN-55-519	1/2	250	5	30	160439



RATCHET WRENCH FOR SOCKETS 1/2"



index					5906757
	inch	mm	pcs	pcs	
MN-55-520	1/2	250	5	30	247840



RATCHET WRENCH FOR SOCKETS 1/2"



9 SOCKET SET WITH RATCHET 1/2"



index	pieces	pcs	pcs	5906757
MN-57-152	10	1	18	907522



mm
10
12
13
14
15
16
17
19
22

9 SOCKET SET 1/2"



index	pieces	pcs	pcs	5906757
MN-57-151	9	1	24	907515



mm
10
12
13
14
15
16
17
19
22

9 SOCKET E-STAR SET 1/2"



index	pieces	pcs	pcs	5906757
MN-57-153	9	1	24	907539



mm
E10
E11
E12
E14
E16
E18
E20
E22
E24

9 SOCKET TORX SET WITH 1/2" DRIVE



index	pieces	pcs	pcs	5906757
MN-57-154	9	1	24	907546



mm	mm
T20	T50
T25	T55
T30	T60
T40	T70
T45	



MECHANICAL TOOL



index			5906675
	sets	sets	
MN-57-318	6	48	000794



	mm	inch
	10,0; 11,0; 12,0; 13,0; 14,0; 15,0; 17,0; 19,0; 21,0; 22,0; 24,0;	1/2
	250	1/2
	200; 125	1/2
	250	1/2
	75	1/2
	16; 21	1/2
	360	1/2

index			5906675
	sets	sets	
MN-57-320	6	48	007717



	mm	inch
	6,0; 8,0; 10,0; 11,0; 12,0; 13,0; 14,0; 15,0; 17,0; 19,0; 21,0; 22,0; 24,0;	3/8
	250	3/8
	125; 75	3/8
	125	3/8
	75	3/8
	16; 21	3/8
	360	3/8

SET OF SOCKET WRENCHES 18 PCS 1/2"



SET OF SOCKET WRENCHES 20 PCS 3/8"











MECHANICAL TOOL

SET OF SOCKET WRENCHES 18 PCS 1/2"



index			5906675
	sets	sets	
MN-57-323	6	48	047522



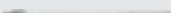



		
	mm	inch
	10,0; 11,0; 12,0; 13,0; 14,0; 15,0; 16,0; 17,0; 19,0; 21,0; 22,0; 24,0; 27,0; 30,0; 32,0	1/2
	250	1/2
	200; 125	1/2
	250	1/2
	75	1/2
	16; 21	1/2
	360	1/2

ADJUSTABL WRENCH SHORT



NEW





index					5906757
	mm	mm	pcs	pcs	
MN-53-100	185	46	6	36	002371

CR-V

ADJUSTABL WRENCH WITH RATCHET







NEW

index					5906757
	mm	mm	pcs	pcs	
MN-53-130	250	30	6	48	002425



ADJUSTABLE WRENCHES





index					5906757
	mm	mm	pcs	pcs	
MN-53-106	150	20	6	48	273153
MN-53-108	200	25	6	24	146693
MN-53-110	250	32	6	24	146709
MN-53-112	300	35	6	24	146716



WHEEL LUG WRENCH 17, 19, 21, 22 MM



index				5906757
	mm	pcs	pcs	
MN-59-001	17, 19, 21, 22	1	20	910348

index	①	📦	📦	5906757
	pieces	sets	sets	
MN-54-102	10	6	48	157248



mm	mm	mm	mm
1,5	45	5	75
2	50	5,5	80
2,5	55	6	95
3	65	8	105
4	70	10	120

10-PIECE HEX KEY SET 1,5-10 MM



index	①	📦	📦	5906757
	pieces	sets	sets	
MN-54-117	9	6	72	272484



mm	mm	mm	mm
1,5	45	5	75
2	50	6	95
2,5	55	8	105
3	60	10	120
4	65		

9-PIECE BALL-END HEX-KEY SET 1,5-10 MM



index	①	📦	📦	5906757
	pieces	sets	sets	
MN-54-118	9	8	48	157231



mm	mm	mm	mm
1,5	75	5	120
2	80	6	140
2,5	85	8	160
3	95	10	180
4	105		

9-PIECE BALL-END HEX-KEY SET 1,5-10 MM



index	①	📦	📦	5906757
	pieces	sets	sets	
MN-54-119	9	6	60	152427



mm	mm	mm	mm
1,5	75	5,0	120
2,0	80	6,0	140
2,5	85	8,0	160
3,0	95	10,0	180
4,0	105		

9-PIECE BALL-END HEX-KEY SET 1,5-10 MM



index	①	📦	📦	5906757
	pieces	sets	sets	
MN-54-121	9	6	60	902091



mm	mm	mm	mm
1,5	75	5	120
2	80	6	140
2,5	85	8	160
3	95	10	180
4	105		

9-PIECE HEX KEY SET 1,5-10 MM



9-PIECE TORX WRENCH SET T10-T50



index	①	📦	📦	5906757
	pieces	sets	sets	
MN-54-106	9	6	72	272408



⚙️	↔️	⚙️	↔️
mm	mm	mm	mm
T10	45	T30	85
T15	50	T40	95
T20	55	T45	105
T25	65	T50	115
T27	70		

9-PIECE TORX WRENCH SET T10-T50



index	①	📦	📦	5906757
	pieces	sets	sets	
MN-54-116	9	6	36	902015



⚙️	↔️	⚙️	↔️
mm	mm	mm	mm
T10	90	T30	160
T15	100	T40	170
T20	110	T45	200
T25	125	T50	220
T27	140		

9-PIECE BALL-END HEX - KEY SET 1,5-10 MM



index	①	📦	📦	5906757
	pieces	sets	sets	
MN-54-120	9	6	36	272415



⚙️	↔️	⚙️	↔️
mm	mm	mm	mm
1,5	90	4,0	140
2,0	100	5,0	160
2,5	110	6,0	175
3,0	125	8,0	200

8-PIECE HEX KEY SET 2-8 MM



index	①	📦	📦	5906757
	pieces	sets	sets	
MN-54-131	8	12	72	903036



⚙️	↔️	⚙️	↔️
mm	mm	mm	mm
2	55	5	70
2,5	60	6	75
3	60	7	80
4	65	8	85

6-PIECE BALL-END HEX-KEY SET 2-6 MM



index	①	📦	📦	5906757
	pieces	sets	sets	
MN-54-132	6	12	72	903043



⚙️	↔️	⚙️	↔️
mm	mm	mm	mm
2	55	4	65
2,5	60	5	70
3	60	6	75

index	①	📦	📦	5906757
	pieces	sets	sets	
MN-54-134	7	12	72	903067



🚫	↔	🚫	↔
mm	mm	mm	mm
T10	55	T27	70
T15	60	T30	75
T20	60	T40	80
T25	65		

7-PIECE TORX WRENCH SET T10-T40



index	📏	📏	nośność/ carrying capacity/ грузоподъем- ностью	📦	📦	5906757
	mm	м/м	t/tons/Тонны	pcs	pcs	
MN-02-503	35	3	2	1	15	090224
MN-02-506	50	6	2	1	7	090187
MN-02-508	50	8	2	1	6	090194
MN-02-510	50	10	2	1	5	090200
MN-02-512	50	12	2	1	5	090217



RATCHET STRAPS

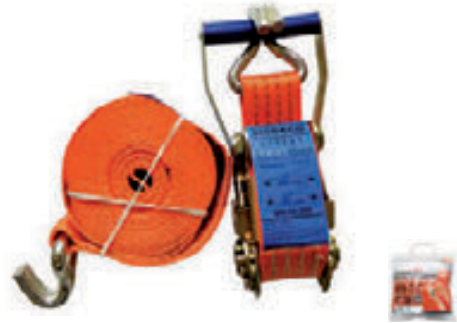

index	📏	📏	nośność/ carrying capacity/ грузоподъем- ностью	📦	📦	5906757
	mm	м/м	t/tons/Тонны	pcs	pcs	
MN-02-612	30	2	1	1	20	000346
MN-02-613	30	3	1	1	20	393896
MN-02-615	30	5	1	1	15	000353
MN-02-621	60	1	2	1	20	000360
MN-02-622	60	2	2	1	15	000377
MN-02-623	60	3	2	1	15	000384
MN-02-624	60	4	2	1	10	000391
MN-02-626	60	6	2	1	8	000407
MN-02-632	90	2	3	1	10	000414
MN-02-633	90	3	3	1	8	000421
MN-02-634	90	4	3	1	5	000438
MN-02-635	90	5	3	1	5	000445
MN-02-636	90	6	3	1	5	000452
MN-02-643	120	3	4	1	8	000773
MN-02-644	120	4	4	1	6	000780
MN-02-645	120	5	4	1	6	000797
MN-02-646	120	6	4	1	6	000803

EYE WEBBING SLING



index	①	📦	📦	5906757
	ml/мл	sets	sets	
MN-09-080	400	1	15	000810



OIL FOR DRILLING AND CUTTING



ZINC SPRAY 400 ML



index	ml/мл	sets	sets	5906757
MN-09-083	400	1	45	000841

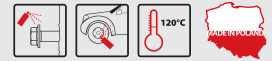

UNIVERSAL LUBRICANT SPRAY 400ML



index	ml/мл	sets	sets	5906757
MN-09-092	400	1	15	270992

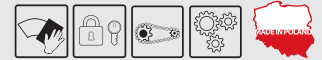

SILICON GREASE 400ML



index	ml/мл	sets	sets	5906757
MN-09-095	400	1	15	064420



GRAPHITE GREASE 400ML



index	ml/мл	sets	sets	5906757
MN-09-096	400	1	15	064437





Measuring instruments must be accurate because they are often used in renovation and finishing work, as well as on construction sites. They make it easy to determine and check the dimensions of parts or clearances.

MEASURING TOOLS

Modeco Expert delivers a wide range of measuring tools which allow you to quickly and conveniently check the length of cut pieces or measure distances. These include high-quality and high-precision measuring tapes, retractable and folding measures, callipers, and angle gauges. They give you the certainty that no mistakes or errors are made during DIY work at home or at the construction site.

Users truly appreciate working with the Modeco Expert measuring tools whose quality and accuracy are confirmed by the certificates they have received and the standards they meet.





TAPE RULES

Retractable measuring tapes perform an important function in construction or any kinds of renovation works. They are designed for measuring distances that do not exceed 10 metres.

Our construction measuring tapes are used by both builders and do-it-yourselfers. In order to meet the customers' requirements, the Modeco Expert offering includes the most accurate measuring tape, PRO CHROM, which complies with the stringent conditions of the EU standards for Class I accuracy. It proves indispensable in most construction and repair works. It features a special tape coating which prolongs its service life and reduces the potential abrasion wear. On top of that, the white measuring tape is well visible during measurements. It is available in three lengths: 3m, 5m, and 8m.

▶ **RUBBERISED CASING**
for increased shock
resistance

CHROMIUM-PLATED BODY ◀
for maximum durability



▶ **SLIDE LOCK**
ensuring improved
retraction control
and extended life

**WHITE MEASURING
TAPE** ◀
ensuring
good visibility during
measurements







▶ **MEASURING TAPE
COMPLIANT WITH
STRINGENT REQUIREMENTS
OF EU STANDARDS AND
HIGH ACCURACY CLASS**
(admissible measuring error of
+0.3mm per 2m)

**SPECIAL ADDITIONAL TAPE
COATING** ◀
for extended service
life and reduced abrasion wear

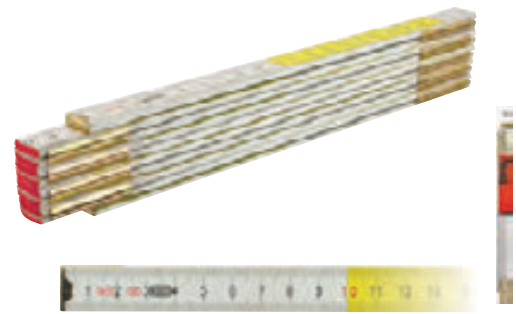
index				5906757
	m	pcs	pcs	
MN-80-151	1	10	240	147317
MN-80-152	2	5	120	147324

FOLDING RULERS





index				5906757
	m	pcs	pcs	
MN-80-162	2	5	100	903029





FOLDING RULER



index				5906675
	m	pcs	pcs	
MN-80-171	1	10	240	034553
MN-80-172	2	5	120	375786





FOLDING RULERS SUPREME



index				5906675
	m	pcs	pcs	
MN-80-212	2	12	120	019925

FOLDING RULER



index					5906675
	m	mm	pcs	pcs	
MN-81-023	3	16	12	72	415000
MN-81-025	5	25	12	72	325064
MN-81-028	8	25	6	48	415017
MN-81-030	10	25	6	48	415031



TAPE RULES SILVER LINE



TAPE RULES SUPREME



index					5906757
	m	mm	pcs	pcs	
MN-81-113	3	16	12	120	148369
MN-81-115	5	19	12	120	148376



TAPE RULES BASIC



index					5906757
	m	mm	pcs	pcs	
MN-81-132	2	16	12	120	162556
MN-81-133	3	16	12	120	162563
MN-81-135	5	25	12	60	162570
MN-81-137	7,5	25	12	60	162587



TAPE RULES BIG STOP



index					5906757
	m	mm	pcs	pcs	
MN-81-143	3	19	10	120	265905
MN-81-145	5	25	10	120	265912
MN-81-148	8	25	10	60	265929



TAPE RULES FRIENDLY GRIP



index					5906757
	m	mm	pcs	pcs	
MN-81-152	2	16	12	144	151352
MN-81-153	3	16	12	144	151345
MN-81-155	5	19	12	72	151369
MN-81-156	5	19	12	72	266209
MN-81-158	8	25	12	48	151376

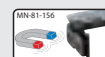





TAPE RULES METAL PROFI



index					5906675
	m	mm	pcs	pcs	
MN-81-183	3	16	12	120	024547
MN-81-185	5	19	12	72	024554
MN-81-186	5	19	12	72	119106
MN-81-188	8	25	6	48	024561







index					5906757
	m	mm	pcs	pcs	
MN-81-203	3	16	12	120	121508
MN-81-205	5	19	12	120	121515
MN-81-208	8	25	6	48	121522



TAPE RULES PRO-CHROM







index					5906757
	m	mm	pcs	pcs	
MN-81-211	10	13	5	30	145689
MN-81-221	20	13	5	20	145696
MN-81-231	30	13	5	20	145702



MEASURING TAPE







index					5906757
	m	mm	pcs	pcs	
MN-81-232	30	13	5	20	151963
MN-81-252	50	13	5	20	151970







SURVEYOR'S MEASURING TAPES FRIENDLY GRIP



index					5906757
	mm	mm	pcs	pcs	
MN-83-020	165	250	6	48	161511
MN-83-022	180	300	6	30	161528
MN-83-024	195	350	6	30	161535
MN-83-026	210	400	6	30	161542

SQUARE RULER



index						5906757
	pieces	mm	mm	pcs	pcs	
MN-83-030	1	100	300	20	60	000872



COMBINATION SQUARE



SQUARE "T"



index						5906757
	pieces	mm	mm	pcs	pcs	
MN-83-040	1	300	600	6	36	000858
MN-83-042	1	500	1000	6	36	000865



ROOFING SQUARE RULER



index					5906757
	mm	mm	pcs	pcs	
MN-83-050	400	600	6	36	272965

CARPENTER'S SQUARE



index						5906757
	pieces	mm	mm	pcs	pcs	
MN-83-055	1	200	300	10	100	000896
MN-83-057	1	400	600	9	27	000902



CARPENTER'S SQUARE 185X185 MM



index					5906757
	mm	mm	pcs	pcs	
MN-83-100	185	185	1	36	000889







CARPENTER'S SQUARE 300X300 MM



index					5906675
	mm	mm	pcs	pcs	
MN-83-102	300	300	10	30	497389



index					5906757
	mm	mm	pcs	pcs	
MN-85-100	150	0,01	6	48	098510
MN-85-101	150	0,01	12	48	902671

stainless steel
graduation mm and inch

ELECTRONIC SLIDE CALIPERS



MN-85-100

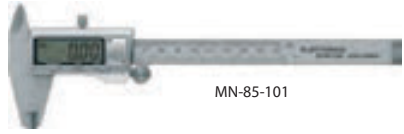

MN-85-101

CONSTRUCTION TOOLS

Work organisation at construction sites or even at home, during renovation work, is a very important stage that actually marks the onset of every project. What matters is to make sure that the high-quality tools delivered by Modeco Expert are securely stored in appropriate conditions, so that they can serve their purpose for a long time.

Construction tools prove useful at every stage of construction work. Additionally, once the project is completed, you can use the tools to create your own structures in the garden or workshop. But it is important to remember that they should be properly secured and maintained, as it affects the comfort and quality of work. The Modeco Expert offering of construction tools is extremely diverse and wide. Some more products worth special attention are high-quality construction floats intended for sanding, smoothing, and troweling of plasters, as well as for finishing of plasters, mortars, and adhesives. To make sure that the surface thus obtained is even, it is necessary to set a level or plumb line using a spirit level. When the work is done, we recommend you to store smaller tools in dedicated containers.





LEVELS

Levels with vials are measuring tools that can be used to mark out a level, a plumb line, an angle of 45°, or an inclination on a surface. They differ in length, number and type of vials, number of handgrips, and cross-section.

The Modeco Expert Basic spirit levels with horizontal and vertical vials are specifically intended for construction work. Their high measurement accuracy of 0.4 mm/m is guaranteed by the shockproof vials. The level vial is made according to an innovative design that ensures easy and quick reading, regardless of the viewing angle. It also has additional rings, as a standard feature, allowing you to establish a 2.3% inclination.

Modeco Expert is committed to high quality, which is why our spirit levels are covered by a lifetime warranty on the vial gluing and the side shock absorbers. Powder coating additionally protects the tool's corrosion-resistant aluminium profile against scratches, while the profile ribbing increases torsion resistance and provides increased resistance to bending. Having gentle shapes and no sharp edges, the tool is extremely easy to clean.

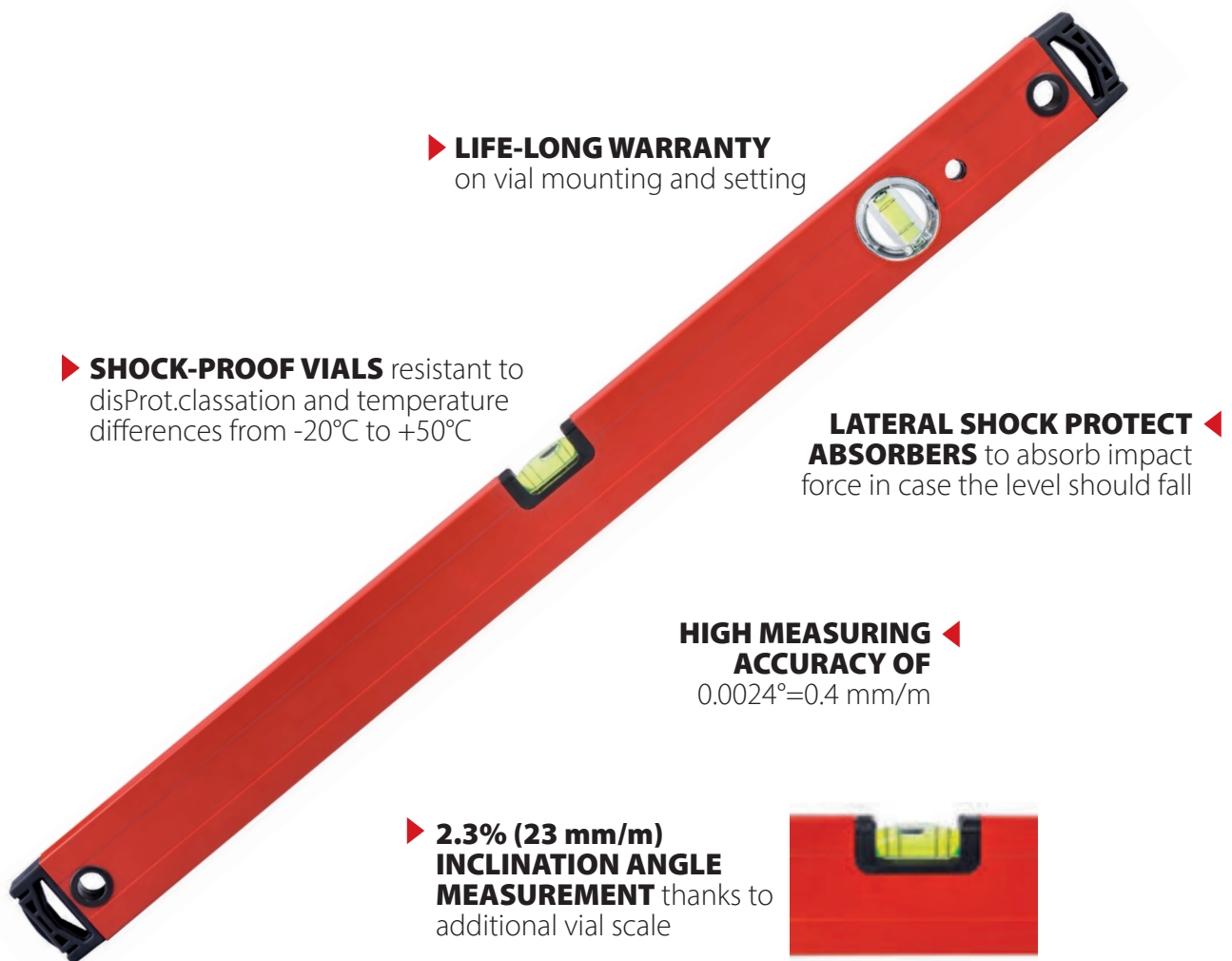

index	5906757		5906757	
	cm	pcs		pcs
MN-70-556	60	1	5	464961
MN-70-558*	80	1	5	464978
MN-70-560*	100	1	5	464985
MN-70-562*	120	1	5	464992
MN-70-565*	150	1	5	001923
MN-70-570*	200	1	5	001930

*2 uchwyty



ANODIZED LEVELS GOLD 90° 0° 45°

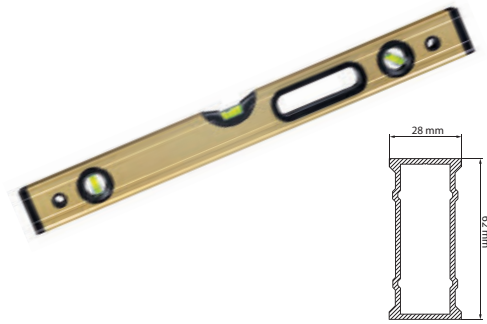

index	5906675		5906675	
	cm	pcs		pcs
MN-70-536	60	1	5	464909
MN-70-538	80	1	5	464916
MN-70-540	100	1	5	464923
MN-70-542	120	1	5	464930
MN-70-545	150	1	5	464947
MN-70-550	200	1	5	464954



ANODIZED LEVELS SILVER 90° 0°

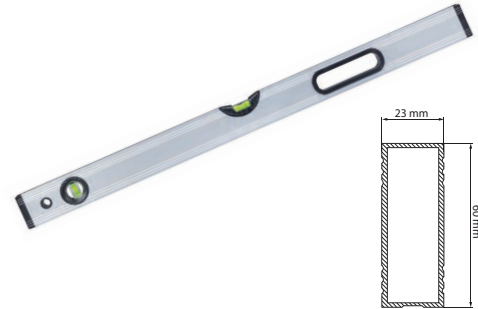

index	5906757		5906757	
	cm	pcs		pcs
MN-70-502	25	5	5	002128



ANODIZED LEVELS SILVER 90° 0°



index	5906675		5906675	
	cm	pcs		pcs
MN-70-504	40	1	5	464831
MN-70-506	60	1	5	464848
MN-70-508	80	1	5	464855
MN-70-510	100	1	5	464862
MN-70-512	120	1	5	464879
MN-70-515	150	1	5	464886
MN-70-520	200	1	5	464893



LEVELS BASIC 90° 0°

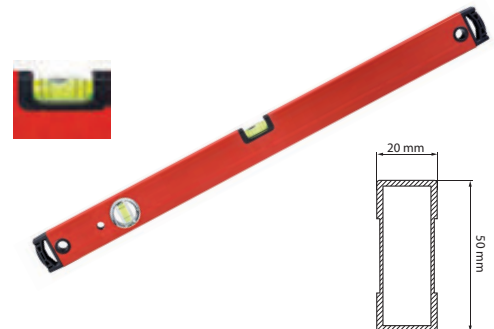

index	5906757		5906757	
	cm	pcs		pcs
MN-71-122	200	1	5	909137
MN-71-127	250	1	5	909144
MN-71-130	300	1	5	909151



BRICKLAYER STAFFS WITH 2 LEVEL WINDOWS



BRICKLAYER STAFFS WITH 2 LEVEL WINDOWS AND 2 HOLDERS



index	cm	pcs	pcs	5906757
MN-71-223	200	1	5	270480
MN-71-227	250	1	5	270497
MN-71-232	300	1	5	270503



BRICKLAYER'S TRAPEZOID STAFFS



index	cm	pcs	pcs	5906757
MN-71-317	150	1	5	270510
MN-71-322	200	1	5	270527
MN-71-327	240	1	5	270534



BRICKLAYER'S SQUARES



index	mm	mm	pcs	pcs	5906757
MN-83-060	600	400	1	5	274877
MN-83-062	1000	500	1	5	274891



BRICKLAYER'S SQUARE



index	mm	mm	pcs	pcs	5906757
MN-83-068	1000	1000	1	5	000995





SANDING SPONGES



index	mm	grain size	pcs	pcs	5906675
MN-73-040	100x70x25	P40	1	250	089188
MN-73-041	100x70x25	P60	1	250	494265
MN-73-042	100x70x25	P80	1	250	494272
MN-73-043	100x70x25	P100	1	250	494289
MN-73-044	100x70x25	P120	1	250	494296
MN-73-045	100x70x25	P150	1	250	494302
MN-73-046	100x70x25	P180	1	250	497921
MN-73-047	100x70x25	P220	1	250	497938





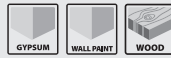

index		grain size			5906675
	mm		pcs	pcs	
MN-73-050	100x70/50x25	P60	1	250	494319
MN-73-051	100x70/50x25	P80	1	250	494326
MN-73-052	100x70/50x25	P100	1	250	494333
MN-73-053	100x70/50x25	P120	1	250	494340
MN-73-054	100x70/50x25	P150	1	250	494357
MN-73-055	100x70/50x25	P180	1	250	497945



SANDING SPONGES



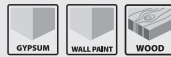

index		grain size			5906675
	mm		pcs	pcs	
MN-73-060	100x100x12	P40	1	250	498041
MN-73-061	100x100x12	P60	1	250	498058
MN-73-062	100x100x12	P80	1	250	498065
MN-73-063	100x100x12	P100	1	250	498072
MN-73-064	100x100x12	P120	1	250	498089
MN-73-065	100x100x12	P150	1	250	498096
MN-73-066	100x100x12	P180	1	250	498102
MN-73-067	100x100x12	P220	1	250	498119



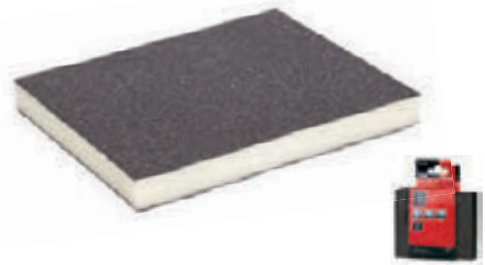

SANDING SPONGES 2 PCS



index					5906675
	mm		pcs	pcs	
MN-72-100	130		20	200	024578



SILICONE FILLER KNIFE



index					5906757
	mm		pcs	pcs	
MN-72-076	60		1	20	901698
MN-72-078	80		1	10	901780
MN-72-080	100		1	10	161283

STAINLESS STEEL SCRAPER PROFI



index					5906675
	mm		pcs	pcs	
MN-72-130	40		1	20	478524
MN-72-131	60		1	20	478531
MN-72-132	80		1	20	478548
MN-72-133	100		1	20	478555
MN-72-134	120		1	20	478562
MN-72-135	150		1	20	478579



STAINLESS STEEL SCRAPER



two-component handle

STAINLESS STEEL SCRAPER WITH PH2 BIT





index				5906675
	mm	pcs	pcs	
MN-72-136	150	1	20	478586



STAINLESS STEEL PLASTER SMOOTHER





index				5906675
	mm	pcs	pcs	
MN-72-370	300	1	10	478593



steel 0,5 mm blade
aluminium guide
two-component handle

STAINLESS STEEL PLASTER SMOOTHER





index				5906675
	mm	pcs	pcs	
MN-72-371	350	1	10	478609
MN-72-372	400	1	10	478616
MN-72-373	450	1	10	478623
MN-72-374	500	1	10	478630
MN-72-375	600	1	10	478647



SKIMMING SPATULAS PVC 0,3 MM





index				5906675
	mm	pcs	pcs	
MN-72-502	250	2	2	469836
MN-72-504	400	2	2	469843
MN-72-506	600	2	2	469850
MN-72-508	800	2	2	469867
MN-72-510	1000	2	2	469874





SKIMMING SPATULAS ALU 0,3 MM



index				5906757
	mm	pcs	pcs	
MN-72-522	250	2	2	002142
MN-72-524	400	2	2	469843
MN-72-526	600	2	2	002166
MN-72-528	800	2	2	002173
MN-72-530	1000	2	2	002180

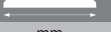



index				5906675
	mm	pcs	pcs	
MN-72-542	250	2	2	469904
MN-72-544	400	2	2	469911
MN-72-546	600	2	2	469928
MN-72-548	800	2	2	469935
MN-72-550	1000	2	2	469942



SKIMMING SPATULA BLADES 0,3 MM





index				5906675
	m	pcs	pcs	
MN-72-580	1,3-2,4	6	24	469973



TELESCOPIC POLE 1,3-2,4 M





index				5906675
	mm	pcs	pcs	
MN-72-581	180	1	4	469980



ADAPTER FOR SKIMMING SPATULA







index				5905629
	mm	pcs	pcs	
MN-74-318	80	1	10	031204
MN-74-320	100	1	10	031297



STAINLESS STEEL TROWELS FOR PLASTER



beech handle
blade: 1,3 mm

index					5906675
	mm	mm	pcs	pcs	
MN-74-210	60	115	1	30	478708
MN-74-211	80	115	1	30	478715
MN-74-212	100	130	1	30	478722





STAINLESS STEEL TROWELS FOR PLASTER



two-component grip

STAINLESS STEEL TRAPEZOID TROWELS





index				5905629
	mm	pcs	pcs	
MN-74-328	180	1	10	031709



beech handle
blade: 1,3 mm

TRAPEZOID TROWEL GROUND - WELDED





index				5906675
	mm	pcs	pcs	
MN-74-160	180	1	50	486932



two-component
blade:
- steel
- hardened

STAINLESS STEEL TRAPEZOID TROWELS WITH RIVET





index				5906675
	mm	pcs	pcs	
MN-74-197	140	1	30	486970
MN-74-198	160	1	30	486987
MN-74-199	180	1	30	486994



two-component handle

TRIANGLE TROWELERS





index				5906757
	mm	pcs	pcs	
MN-74-218	180	1	20	072251
MN-74-219	190	1	20	072268
MN-74-220	200	1	20	072275
MN-74-221	210	1	20	072282



wood handle
edge:
- hardened
- 1,2mm



TRIANGLE TROWELERS



index				5906675
	mm	pcs	pcs	
MN-74-163	160	1	50	486956
MN-74-164	200	1	50	486963



two-component grip
edge:
- steel
- hardened

index				5906675
	mm	pcs	pcs	
MN-74-303	8	1	80	478739
MN-74-304	10	1	80	478746
MN-74-305	12	1	80	486451



two-component grip

index				5906757
	mm	pcs	pcs	
MN-74-208	60x100	1	30	900721



two-component grip

index				5906757
	mm	pcs	pcs	
MN-74-209	60x100	1	30	900738



two-component grip

TROWELS FOR PLASTER



TROWELS FOR INTERNAL EDGES



TROWELS FOR EXTERNAL EDGES



CONSTRUCTION FLOATS

Construction floats are tools widely used in renovation and construction works. They are used for applying, trowelling, grinding and smoothing mortars, adhesives, plasters and finishing coats.

Each user - a DIY enthusiast, a tiler, a painter and a bricklayer, will appreciate the high-quality workmanship of the floats and the fact that each of them, regardless of the type and the purpose, has an ergonomic, two-component and cambered handle. This is what improves the comfort of work, which is extremely important in the case of construction and finishing works. The Modeco Expert float with a specially made durable grater is designed for grinding polystyrene boards. It is made of hardened plastic, which ensures rigidity of the structure during operation. It is distinguished by a lightweight, through-hole design that ensures easy cleaning and a longer tool life.

- ▶ **ERGONOMIC, TWO-COMPONENT AND CAMBERED HANDLE** improves the comfort of work

- ◀ **FLOAT WITH A SPECIALLY MADE DURABLE GRATER** is designed for grinding polystyrene boards



- ◀ **LIGHTWEIGHT, THROUGH-HOLE DESIGN** that ensures easy cleaning and a longer tool life

- ▶ **MADE OF HARDENED PLASTIC,** which ensures rigidity of the structure during operation

index					5906757
	mm	mm	pcs	pcs	
MN-73-260	380	130	1	14	128811
MN-73-380	480	130	1	14	150263
MN-73-370	580	130	1	14	159600
MN-73-395	680	130	1	14	271487



beech, varnish handle

STAINLESS STEEL FLOATS

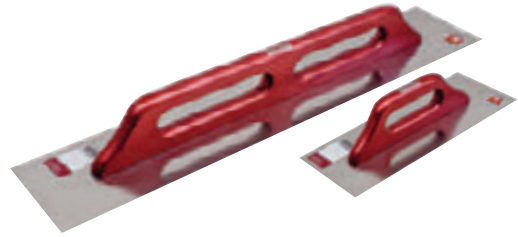

CONSTRUCTION TOOLS

index						5906757
	mm	mm	mm	pcs	pcs	
MN-73-386	480	130	6 x 6	1	14	152298
MN-73-388	480	130	8 x 8	1	14	152304
MN-73-390	480	130	10 x 10	1	14	152311



beech varnish handle
7 bolts fastening

STAINLESS STEEL SERRATED FLOATS



index					5906757
	mm	mm	pcs	pcs	
MN-73-400	280	130	1	24	158252



beech handle

STAINLESS STEEL SERRATED FLOATS



index						5906757
	mm	mm	mm	pcs	pcs	
MN-73-406	280	130	6 x 6	1	24	158276
MN-73-408	280	130	8 x 8	1	24	158283
MN-73-410	280	130	10 x 10	1	24	158290



beech handle

STAINLESS STEEL SERRATED FLOATS



index			5906757
	pcs	pcs	
MN-73-420	1	10	001350

FLOATS



2 pcs
180x130x2 mm i 135x90x2 mm





SPATULA



index					5906757
	mm	mm	pcs	pcs	
MN-73-421	50, 75, 100, 120 mm		1	10	001367

STAINLESS STEEL FLOATS







index					5906675
	mm	mm	pcs	pcs	
MN-73-330	270	130	1	30	478654



tarnamid handle
two-component grip

STAINLESS STEEL SERRATED FLOATS



index						5906675
	mm	mm	mm	pcs	pcs	
MN-73-336	270	130	6x6	1	30	478661
MN-73-338	270	130	8x8	1	30	478678
MN-73-340	270	130	10x10	1	30	478685
MN-73-339	270	130	12x12	1	30	001961
MN-73-341	270	130	R10	1	30	478692



tarnamid handle
two-component grip

STAINLESS STEEL FLOATS







index					5906675
	mm	mm	pcs	pcs	
MN-73-371	200	85	1	30	486925







aluminium handle
two-component grip
ensures streak-free
finishing of venetian
plasters (does not
leave smudges)

PLASTIC PLASTERING FLOAT



index					5906757
	mm	mm	pcs	pcs	
MN-73-102	280	130	1	14	001091

for traditional and
structural plasters





index	 mm	 mm	 mm	 pcs	 pcs	5906757
MN-73-107	250	100	10	1	11	001077



for tiling works

PLASTIC FLOAT WITH PROFILED RUBBER





index	 mm	 mm	 mm	 pcs	 pcs	5906757
MN-73-115	280	140	18	1	15	001008



for tile cleaning
after grouting

PLASTIC FLOAT WITH FOAM RUBBER







index	 mm	 mm	 mm	 pcs	 pcs	5906757
MN-73-130	280	140	8	1	10	001046



for traditional
plasters

PLASTIC FLOAT WITH FLEECE







index	 mm	 mm	 mm	 pcs	 pcs	5906757
MN-73-160	280	140	30	1	14	001015



for tile cleaning
after grouting

PLASTIC FLOAT WITH HYDRO SPONGE 30 MM



index	 mm	 mm	 mm	 pcs	 pcs	5906757
MN-73-162	280	140	30	1	14	001022







for tile cleaning after
grouting

PLASTIC FLOAT WITH HYDRO SPONGE



PLASTIC FLOAT WITH SPONGE 40 MM







index						5906757
	mm	mm	mm	pcs	pcs	
MN-73-165	280	140	40	1	10	001053



do zmywania płytek po fugowaniu for tile cleaning after grouting для чистки плитки

PLASTIC FLOAT FOR POLYSTYRENE FOAM GRINDING



index					5906757
	mm	mm	pcs	pcs	
MN-73-178	380	160	1	12	001060



ALUMINIUM WALL PLANE



index					5906675
	mm	mm	pcs	pcs	
MN-73-182	450	90	1	5	197180



PLASTER SCRAPER





index					5906675
	mm	mm	pcs	pcs	
MN-73-185	285	145	1	30	001084



AIR BLEED ROLLERS



index				5906757
	pcs	pcs	pcs	
MN-73-193	250	1	15	161252
MN-73-194	500	1	10	161269



index				5906675
	litr/ m/ литр	pcs	pcs	
MN-79-221	24	1	1	064581



TILING KIT 24 L



index						5906757
	mm	mm	mm	pcs	pcs	
MN-75-071	600	165	16	1	1	275645



45 degree angle
steel base
bearings
light structure
2 solid steel
guides 20x10 mm
Cutting wheel ø16mm

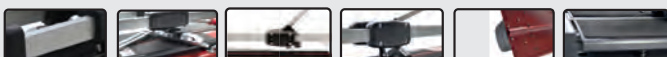

TILE CUTTERS



index						5906757
	mm	mm	mm	pcs	pcs	
MN-75-242	600	200	16	1	1	051116
MN-75-243	800	200	16	1	1	051130



square
steel base
shock absorber
2 solid steel
guides 20x10 mm
Cutting wheel ø8mm

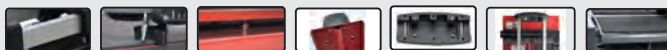

TILE CUTTERS



index						5906757
	mm	mm	mm	pcs	pcs	
MN-75-246	600	265	16	1	1	060576
MN-75-247	800	265	16	1	1	060583



bearings
shock absorber
45° angle
steel base
hinged base
cushioned base
2 solid rectangular guide 25x12 mm
the support for bigger tiles
cutting wheel ø8mm







TILE CUTTERS



TILE CUTTERS







index	 mm	 mm	 mm	 pcs	 pcs	5906757
MN-75-286	600	265	16	1	1	268418
MN-75-288	800	265	16	1	1	268425
MN-75-290	1200	265	16	1	1	909328

square
steel base
shock absorber
2 solid aluminium guides
30x12 mm
Cutting wheel ø8mm



CUTTING WHEELS FOR TILE CUTTERS



index	 mm	 mm	 mm	 pcs	 pcs	5906757
MN-75-502	15	6	1,5	20	200	157606
MN-75-503	16	6	3,0	20	200	157613
MN-75-504	22	6	2,0	20	200	157620

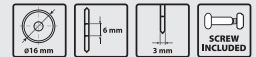



SPARE TILE CUTTING KNIFE 500, 600, 800, 1200 MM



index	 pcs	 pcs	5906757
MN-75-511	20	20	163157

HALF ROUND TUNGSTEN FILE 150 MM





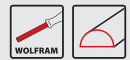

index	 mm	 pcs	 pcs	5906675
MN-65-148	150	10	100	014517



SCRAPER WITH TWO TUNGSTEN BLADES



index	 mm	 mm	 pcs	 pcs	 opak.	5906675
MN-76-130	2	4	2	10	100	014531

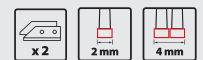

index	grain size	pcs	pcs	5906675	
	mm				
MN-76-320	95x60x30	P60	20	80	494203
MN-76-322	95x60x30	P120	20	80	494210
MN-76-324	95x60x30	P200	20	80	494227
MN-76-326	95x60x30	P400	20	80	494234



DIAMOND HAND BLOCKS



index	pcs	pcs	5906675
MN-76-473	1	10	527062

TILES LEVELING SYSTEM PLIERS



index	pcs	pcs	pcs	Pack	5906675	
MN-76-442	1	-	100	1	16	526942
MN-76-444	1	-	300	1	16	526973
MN-76-440	1	50	50	1	16	527000
MN-76-450	1,5	-	100	1	16	527031
MN-76-452	1,5	-	300	1	12	526959
MN-76-448	1,5	50	50	1	12	526980
MN-76-458	2	-	100	1	12	527017
MN-76-460	2	-	300	1	12	527048
MN-76-456	2	50	50	1	12	526935
MN-76-466	3	-	100	1	12	526966
MN-76-468	3	-	300	1	12	526997
MN-76-464	3	50	50	1	12	527024
MN-76-470	-	100	-	1	10	527055

TILES LEVELING SYSTEM



index	mm	pcs	pcs	Pack	5906757
MN-76-016	1,0	200	1	100	5906675271569
MN-76-000	1,5	200	1	100	166745
MN-76-001	2,0	200	1	100	110830
MN-76-002	2,5	200	1	100	110847
MN-76-003	3,0	150	1	100	110854
MN-76-004	4,0	100	1	100	110861
MN-76-005	5,0	100	1	100	110878

TILE SPACERS

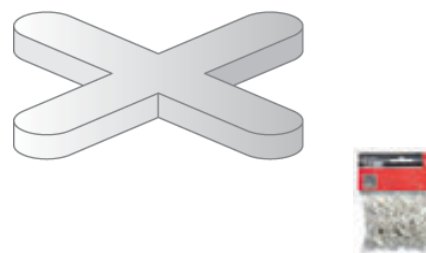

index	mm	pcs	pcs	Pack	5906757
MN-76-016/C	1,0	200	90	90	5906675271569
MN-76-000/C	1,5	200	90	90	166745
MN-76-001/C	2,0	200	90	90	110830
MN-76-002/C	2,5	200	90	90	110847
MN-76-003/C	3,0	150	90	90	110854
MN-76-011/C	-	50	90	90	268203
MN-76-017/C	1,0; 1,5; 2,0; 2,5; 3,0 + klin	50-200	90	90	271569

TILE SPACERS

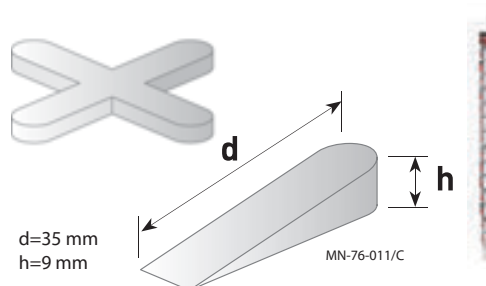

15 bags on a clipstrip
6 clipstrips in the package

TILE WEDGE SPACERS

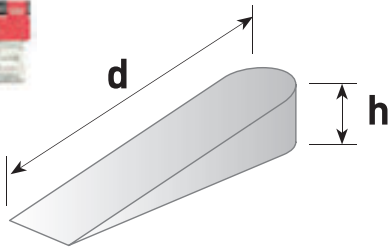

index	①	d	h				5906757
		mm		pcs	pcs	Pack	
MN-76-010	small	27	6	100	1	100	110885
MN-76-011	big	35	9	50	1	100	905726



TILE SPACERS TO CLINKER



index					5906675
	mm	pcs	pcs	Pack	
MN-76-013	8	30	1	100	078342
MN-76-014	10	30	1	100	078359



LIGHT DUTY APPLICATION GUN



index				5906757
	inch(mm)	pcs	pcs	
MN-79-011	9 (230)	12	24	155350



LIGHT DUTY APPLICATION GUN 9"/230 MM



index				5906757
	inch(mm)	pcs	pcs	
MN-79-012	9 (230)	6	24	903371



LIGHT DUTY APPLICATION GUN 9"/230 MM



index				5906675
	mm	pcs	pcs	
MN-79-013	230	6	24	023847



index				5906675	
	pcs	m	pcs	pcs	
MN-79-032	1	100	10	120	535586



BRICK LINE



NEW

Available 09.2024

index				5906757	
	pcs	m	pcs	pcs	
MN-79-018	2	30	6	24	268487



BRICK LINE 30M WITH BLUE CHALK + 115G CHALK



index		section			5906757
	mm		pcs	pcs	
MN-88-015	180		12	144	271098
MN-88-018	240		12	144	271104

CARPENTER'S PENCILS



index		section			5906757
	mm		pcs	pcs	
MN-88-022	180		12	144	271111
MN-88-026	240		12	144	271128

MASONRY PENCILS



index					5906757
	mm		pcs	pcs	
MN-88-032	120		12	432	271142
MN-88-033	120		12	432	900219
MN-88-034	120		12	432	900226
MN-88-035	120		12	432	900233
MN-88-036	120		12	432	900226

CHALK



OIL CONSTRUCTION MARKER



index	mm		pcs	pcs	5906757
MN-88-080	2-3,6		1	20	001107
MN-88-081	2-3,6		1	20	001121
MN-88-082	2-3,6		1	20	001145
MN-88-083	2-3,6		1	20	001169
MN-88-080/T	2-3,6		12	72	001114
MN-88-081/T	2-3,6		12	72	001138
MN-88-082/T	2-3,6		12	72	001152
MN-88-083/T	2-3,6		12	72	001176



CHALK MARKER



index	mm		pcs	pcs	5906757
MN-88-090	2-3		1	20	001183
MN-88-091	2-3		1	20	001190
MN-88-090/T	2-3		10	50	001220
MN-88-091/T	2-3		10	50	001237







PERMANENT MARKER



index	mm		pcs	pcs	5906757
MN-88-100	1,5-3		1	20	001206
MN-88-101	1,5-3		1	20	001213
MN-88-100/T	1,5-3		12	60	001244
MN-88-101/T	1,5-3		12	60	001251







index					5906757
	mm	m	pcs	pcs	
MN-05-136	38	33	1	48	272156
MN-05-138	50	33	1	36	272163



MASKING TAPES







index					5906675
	mm	m	pcs	pcs	
MN-05-140	25	25	6	72	013422
MN-05-142	38	25	6	48	013459
MN-05-144	48	25	6	36	013466



MASKING TAPES







index					5906757
	mm	m	pcs	pcs	
MN-05-232	38	25	6	48	000940
MN-05-234	50	25	6	36	000957
MN-05-236	38	10	6	48	000964
MN-05-238	50	10	6	36	000971



DOUBLE-SIDED STRENGTHENED TAPE







index					5906675
	mm	m	pcs	pcs	
MN-05-250	19	5	1	90	437194
MN-05-252	19	1,5	1	90	437200



DOUBLE-SIDED MOUNTING TAPE



index					5906757
	mm	m	pcs	pcs	
MN-05-330	48	10	6	48	267350
MN-05-332	48	25	6	48	268395
MN-05-334	48	50	6	24	910379



PACKING TAPES DUCT TAPE



PACKING TAPES DUCT TAPE



index	mm	m	pcs	pcs	5906757
MN-05-340	48	10	6	36	910362



UNIVERSAL PLASTERING TAPE



index	mm	m	pcs	pcs	5906675
MN-05-350	38	20	6	48	437132
MN-05-351	38	50	1	32	437149
MN-05-353	48	25	6	36	437170
MN-05-352	48	50	1	24	437163



WARNING TAPE



index	mm	m	pcs	pcs	5906757
MN-05-605	75	100	1	42	155046



INSULATION TAPE



MN-05-006

MN-05-008



MN-05-009

MN-05-010

index	mm	m	pcs	pcs	5906757
MN-05-006	15	10	10	100	159655
MN-05-008	19	20	8	96	070790
MN-05-009	19	20	8	96	001664
MN-05-010	19	20	8	96	001671



SELF-ADHESIVE PROTECTIVE FILM 45 µm



index	mm	m	pcs	pcs	5906757
MN-05-640	250	30	1	12	002043
MN-05-641	500	75	1	6	002050



index				5906757
	mm	pcs	pcs	
MN-79-100	160x100	1	20	086586

MASONRY HOOK FOR TRAVERSING



index		a x b			5906757
	mm	mm	pcs	pcs	
MN-79-161	300	22x16	1	6	903678
MN-79-162	450	30x16	1	6	903685
MN-79-163	600	30x16	1	6	903692
MN-79-164	750	30x16	1	6	903708
MN-79-165	900	30x16	1	6	903715



FORGED CROWBAR WITH NAIL-PULLER

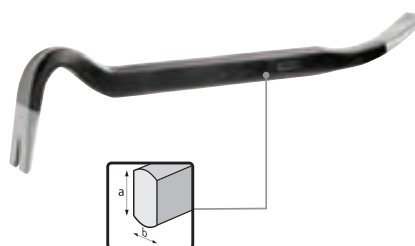

index				5906757
	mm	pcs	pcs	
MN-02-460	60	10	60	143586
MN-02-475	75	10	60	143593
MN-02-490	90	6	36	143609

BRASS BOLT PADLOCKS EXTRA LOCK



index				5906675
	m	pcs	pcs	
MN-79-355	1,1	1	6	023854



SQUARE SHOVEL FIBERGLASS



index				5906675
	m	pcs	pcs	
MN-79-356	1,1	1	6	023861





ROUND NOSE SHOEL FIBERGLASS



COAL SHOVEL FIBERGLASS





index				5906675
	m	pcs	pcs	
MN-79-357	1,1	1	6	23878



FOUR-PRONGED FORK FIBERGLASS





index				5906675
	m	pcs	pcs	
MN-79-358	1,1	1	6	023885



RAKE FORGED FIBREGLASS



index				5906675
	m	pcs	pcs	
MN-79-405	1,5	1	6	083179



RAKE FORGED FIBREGLASS





index				5906675
	m	pcs	pcs	
MN-79-406	1,5	1	6	083186





SQUARE SHOVEL



index				5906757
	m	pcs	pcs	
MN-79-360	1,15	1	6	904934





index				5906757
	m	pcs	pcs	
MN-79-365	1,15	1	6	904941



ROUND NOSE SHOEL





index				5906757
	m	pcs	pcs	
MN-79-370	1,15	1	6	904965



COAL SHOVEL



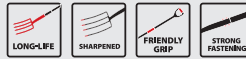

index				5906757
	m	pcs	pcs	
MN-79-375	1,5	1	6	904958



FOUR-PRONGED FORK





index	a	b	c			5906675
	mm	mm	mm	pcs	pcs	
MN-79-400	1230	200	295	1	6	083131

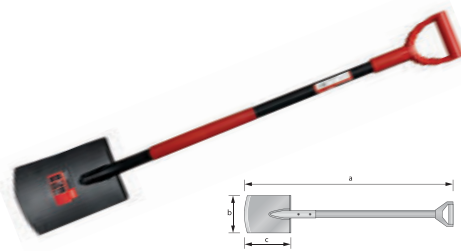

HARDENED SPADE



index	a	b	c			5906675
	mm	mm	mm	pcs	pcs	
MN-79-401	1230	200	295	1	6	083148



ROUND NOSE SHOEL

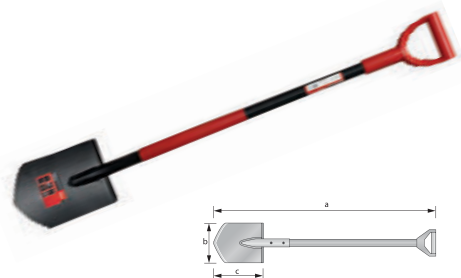

SAND SHOVEL

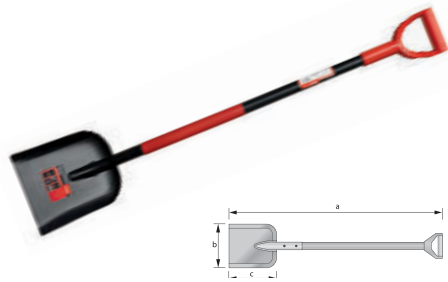

index	a	b	c			5906675
	mm	mm	mm	pcs	pcs	
MN-79-402	1230	245	295	1	6	083155



COAL SHOVEL

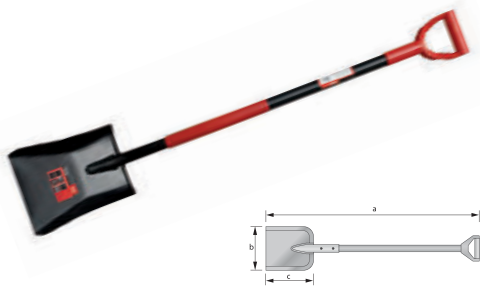

index	a	b	c			5906675
	mm	mm	mm	pcs	pcs	
MN-79-403	1230	245	295	1	6	083162



STREET BROOMERS WITH A HANDLE



index				5906757
	mm	pcs	pcs	
MN-71-802	400	1	10	905795
MN-71-803	500	1	10	905801
MN-71-804	600	1	10	905818



STREET BROOM STICK 1,3 M



index	L			5906757
	m	pcs	pcs	
MN-71-804-A	1,3	1	10	905825

GOATSKIN WORK GLOVES



index	size			5906757
		pcs	pcs	
MN-06-150/10	10"	12	12	909472
MN-06-150/9	9"	12	12	909465



index	size	pcs	pcs	5906757
MN-06-171/11	10,5"	12	12	909533



LINED COWHIDE GLOVES LUX



index	size	pcs	pcs	5906757
MN-06-164/9	9"	12	12	909762



LATEX-COVERED FLEXIBLE GLOVES



index	size	pcs	pcs	5906675
MN-06-210	10,5"	12	120	088259



WHITE COTTON RUBBER COATED GLOVES



index	size	pcs	pcs	5906675
MN-06-212	10"	12	240	088266
MN-06-212/9	9"	12	240	393834



RED POLYESTER WITH BLACK LATEX COATED GLOVES



index	size	pcs	pcs	5906675
MN-06-214	10"	12	240	088273
MN-06-214/9	9"	12	240	393841



GREY POLYESTER WITH GREY NITRILE COATED GLOVES



GREY SHELL WITH BLUE LATEX COATED GLOVES



index	size	5906675		
		pcs	pcs	
MN-06-216	10"	12	120	088280
MN-06-216/9	9"	12	120	393858



BLUE POLYESTER WITH BLACK NITRILE COATED GLOVES



index	size	5906675		
		pcs	pcs	
MN-06-218	10"	12	240	088297
MN-06-218/9	9"	12	240	393865



BLACK POLYESTER WITH BLACK POLYURETHAN COATED GLOVES



index	size	5906675		
		pcs	pcs	
MN-06-220	10"	12	240	088303
MN-06-220/9	9"	12	240	393872



SAFETY HELMET



index	5906757		
	pcs	pcs	
MN-06-145-1	1	40	001800



Material: ABS
 Protection: 1000 V (AC), 1500 V (DC)
 Reflective straps
 6 points textil harness
 Vents
 4 points chin strap

SAFETY HELMET



index	colour	5906757		
		pcs	pcs	
MN-06-143-1	●	1	60	001947
MN-06-143-2	●	1	60	001763
MN-06-143-3	●	1	60	001770



Material: HDPE
 Weight 0,318 kg
 Protection: 1000 V (AC) 1500 V (DC)
 The chin strap is an additional option:
 Four-point MN-06-140-2

index	colour	pcs	pcs	5906757
MN-06-144-1		1	56	001954
MN-06-144-2		1	56	001787
MN-06-144-3		1	56	001794



Material: HDPE

Weight 0,318 kg

Protection: 1000 V
(AC) 1500 V (DC)

Protection: 1000 V (AC) 1500
V (DC)

SAFETY HELMET



index	pcs	pcs	5906757
MN-06-140-2	1	500	001824



matches
MN-06-143 and MN-06-144

4-POINT STRAP



index	pcs	pcs	5906757
MN-06-109	1	15	267428



FACE SHIELD OTP-1



index	Prot.class	colour	pcs	pcs	5906757
MN-06-610	FFP1		3	300	67245
MN-06-611	FFP2		3	300	67252
MN-06-612	FFP3		2	300	67269

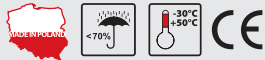

FILTERING HALF MASK WITH VALVE



NEW

index	Prot.class	pcs	pcs	5906757
MN-06-621	FFP2	2	300	67283



FILTERING HALF-MASK WITH VALVE AND ACTIVE CARBON



NEW

Active carbon absorbs
odours

PROTECTIVE EAR MUFFS 27 dB



index			5906757
	pcs	pcs	
MN-06-205	12	48	119604



SILICONE FILLED PROTECTIVE KNEE PADS 2 PCS



index			5906757
	pcs	pcs	
MN-06-303	6	12	904781



SILICONE FILLED PROTECTIVE KNEE PADS 2 PCS



NEW

index			5906675
	pcs	pcs	
MN-06-306	6	12	5491714



SILICONE FILLED PROTECTIVE KNEE PADS 2 PCS



NEW

index			5906675
	pcs	pcs	
MN-06-307	6	12	491721



The Modeco Expert Multi Storage System is a perfect solution for all hand tool users.

Seeking to organise and protect your tools, so that they are also available for everyday repair work, you will surely appreciate the Multi Storage System of modular portable toolboxes from Modeco Expert. The system consists of 7 elements: 2 alternative transport systems – a wheeled box and a transport platform, a toolbox, a larger and a smaller open box, and two organisers.

To accommodate each user's unique needs, the system comprises boxes of 3 sizes and capacities of 14.3, 26, and 38 litres, allowing you to choose the right size to suit your individual preferences. But the greatest advantage of the MULTI STORAGE SYSTEM is that all boxes are fully compatible with one another, so you can stack them like bricks, one on top of the other, to build your customised set.

3 BOX CAPACITIES: 14.3, 26, and 38 l

REMOVABLE INNER COMPARTMENT SEPARATORS for easy space organisation

HIGH-PRECISION POLYAMIDE LID LATCHES without sharp edges

COMPATIBLE BOXES which can be stacked like bricks, one on top of the other, to build customised sets

2 ALTERNATIVE TRANSPORT SYSTEMS featuring a wheeled box and a transport platform

TOOL TRANSPORT ACCESSORIES

**MODULAR PORTABLE
TOOL BOX SYSTEM**
consisting of 7
components

**TELESCOPIC WHEELED
BOX HANDLE** for easy
transport and storage



TOOL BOX SYSTEM - ORGANISER 14,3 L



index	size	cap.			5906675
	mm	l	pcs	pcs	
MN-03-170	530x310x130	14,3	1	1	456409

polycarbonate transparent cover
9 removable small bins
reinforced ribbed construction
strong and durable side connectors
polyamide latches
14,3 l capacity
handle lock in 90° position

TOOL BOX SYSTEM - TOOL BOX 26 L



index	size	cap.			5906675
	mm	l	pcs	pcs	
MN-03-171	530x313x223	26	1	1	456416

reinforced ribbed construction
strong and durable side connectors
polyamide latches
26 l capacity
handle lock in 90° position
2 removable dividers

TOOL BOX SYSTEM - WHEELED BOX 38 L



index	size	cap.			5906675
	mm	l	pcs	pcs	
MN-03-172	530x385x690	38	1	1	456423

reinforced ribbed construction
strong and durable side connectors
polyamide latches
38 l capacity
handle lock in 90° position
2 removable dividers
telescopic handle

TOOL BOX SYSTEM - OPEN BOX 14,3 L



index	size	cap.			5906675
	mm	l	pcs	pcs	
MN-03-173	530x310x130	14,3	1	1	456430

reinforced ribbed construction
strong and durable side connectors
5 removable dividers
14,3 l capacity

TOOL BOX SYSTEM - OPEN BOX 26 L



index	size	cap.			5906675
	mm	l	pcs	pcs	
MN-03-174	530x295x195	26	1	1	456447

reinforced ribbed construction
strong and durable side connectors
2 removable dividers
26 l capacity

index	size			5906675
	mm	pcs	pcs	
MN-03-175	595x395x175	1	1	456454

reinforced ribbed construction
strong and durable side connectors
max. load capacity 100 kg
4 wheels rotating 360°
2 wheels equipped with brakes

TOOL BOX SYSTEM - TRANSPORT PLATFORM



index	size			5906675
	mm	pcs	pcs	
MN-03-176	257x180x65	1	1	456461

polycarbonate transparent cover
6 removable dividers
fits into MN-03-171 (4 pcs.)
fits into MN-03-174 (6 pcs.)

TOOL BOX SYSTEM - SMALL ORGANISER



index					5906757
	mm	pcs	pcs	pcs	
MN-03-110	430x220x200	2	1	6	908536



TOOL BOX



index					5906757
	mm	pcs	pcs	pcs	
MN-03-112	510x255x235	2	1	4	908543



TOOL BOX



index				5906757
	mm	pcs	pcs	
MN-03-460	610x300x280	1	10	910287



TOOL BAG



TOOL BAG



index	①	📦	📦	5906757
	mm	pcs	pcs	
MN-03-464	460x280x300	1	10	910294



TOOL BAG



index	①	📦	📦	5906757
	mm	pcs	pcs	
MN-03-466	500x230x280	1	4	910300



LEATHER TOOL BELT



index	📦	📦	5906675
	pcs	pcs	
MN-03-218	5	30	377704



HAMMER HOLDER LEATHER



index	📦	📦	5906675
	pcs	pcs	
MN-03-219	1	50	509624





NAIL POCKET LEATHER



index	📦	📦	5906675
	pcs	pcs	
MN-03-220	1	50	509631



index			5906757
	pcs	pcs	
MN-03-401	6	72	273412

CLIP & BELT LOOP 80-140 CM



index			5906757
	pcs	pcs	
MN-03-406	6	72	273429

HAMMER HOLDER POUCH



index			5906757
	pcs	pcs	
MN-03-416	6	60	273443

DRILL POUCH



index			5906757
	pcs	pcs	
MN-03-421	6	60	273450

NAIL POUCHES



index			5906757
	pcs	pcs	
MN-03-422	6	60	273467

NAIL POUCHES



UNIVERSAL TOOL APRON



index			5906757
	pcs	pcs	
MN-03-426	6	60	273474



UNIVERSAL TOOL APRON





index			5906757
	pcs	pcs	
MN-03-427	6	60	273481



PLASTERBOARD INSTALLER TOOL BELT





index				5906757
	pieces	pcs	pcs	
MN-03-451	4	1	6	274839



					
	pcs		pcs	pcs	
	1		1		1
					1

ROOFER'S TOOL BELT



index				5906757
	pieces	pcs	pcs	
MN-03-452	3	1	6	274846



					
	pcs		pcs	pcs	
	1		1		1



MODECO
EXPERT

MODECO
EXPERT

5m x 19mm

5m

CUTTING TOOLS

Some of the most typical activities performed in workshops and on construction sites are wood working as well as cutting of metal, aerated concrete, plasterboard, and wood-based materials

Because of such a wide range of applications, one should always rely on cutting tools whose high quality is guaranteed by the manufacturer. And this is precisely the case of the Modeco Expert cutting tools. The Modeco Expert portfolio includes knives, shears, cold chisels, saws, thread cutters, and wood chisels. They are safe and comfortable to use, and made of solid materials such as stainless steel and tool steel.

The Modeco Expert knives can be used in both household and professional work-shops. They differ not only in construction, but also in the blade type, which directly affects their application and handling. Our offering includes aluminium and two-component knives with trapezoidal, trapezoidal-hook, and broken blades.



Some tougher materials, such as metal sheets and steel sections, can be successfully worked using the Modeco Expert shears, which are divided into left- and right-handed, depending on the blade geometry. Thanks to their articulated design, less force is required during cutting, which makes the work easier.





UTILITY KNIFE WITH DETACHABLE SEGMENTED BLADE 9MM





index				5906757
	mm	pcs	pcs	
MN-63-011	9	12	240	269187



UTILITY KNIFE WITH DETACHABLE SEGMENTED BLADE 18MM





index				5906757
	mm	pcs	pcs	
MN-63-021	18	12	96	269194



UTILITY KNIFE WITH DETACHABLE SEGMENTED BLADE 18MM





index				5906675
	mm	pcs	pcs	
MN-63-026	18	6	144	038209



UTILITY KNIFE WITH DETACHABLE SEGMENTED BLADE 18MM





index				5906675
	mm	pcs	pcs	
MN-63-027	18	6	144	038209





NEW
Available 09.2024

UTILITY KNIFE WITH DETACHABLE TRAPEZOID BLADE



index				5906757
	mm	pcs	pcs	
MN-63-034	19x61	12	48	267381





index				5906675
	mm	pcs	pcs	
MN-63-040	19x61	6	72	038186



ALU KNIFE WITH DETACHABLE TRAPEZOID BLADE





index				5906675
	mm	pcs	pcs	
MN-63-042	19x61	6	72	038193



UTILITY KNIFE WITH DETACHABLE TRAPEZOID BLADE



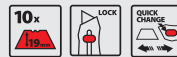

index				5906675
	mm	pcs	pcs	
MN-63-039	19x50	6	72	038230



ALU KNIFE WITH DETACHABLE TRAPEZOID BLADE



index				5906757
	mm	pcs	pcs	
MN-63-041	25	12	120	269156



UTILITY KNIFE WITH DETACHABLE SEGMENTED BLADE 25 MM



in1					5906757
	mm	pcs	pcs	pcs	
MN-63-121	9	10	12	360	268876

SEGMENTED BLADES 9 MM GOLD LINE



SEGMENTED BLADES 18MM GOLD LINE



index					5906757
	mm	pcs	pcs	pcs	
MN-63-124	18	10	12	288	268883
MN-63-125	18	10	50	300	268890
MN-63-126	18	50	12	72	268975

TRAPEZOID BLADES GOLD LINE



index					5906757
	mm	pcs	pcs	pcs	
MN-63-127	19x61	10	12	240	268906

TRAPEZOID HOOK BLADE GOLD LINE



index					5906757
	mm	pcs	pcs	pcs	
MN-63-130	19x50	10	12	240	268920
MN-63-131	19x50	10	1	300	268944

SEGMENTED HOOK BLADES 18 MM



index					5906757
	mm	pcs	pcs	pcs	
MN-63-133	18	10	12	288	268937





SEGMENTED BLADES 25MM GOLD LINE





index					5906757
	mm	pcs	pcs	pcs	
MN-63-137	25	10	12	120	268968



index				5906757
	mm	pcs	pcs	
MN-63-327	190	12	120	246317
MN-63-328	210	12	120	246324
MN-63-329	240	12	120	246331

OFFICE SCISSORS





index	d	h			5906757
	mm	mm	pcs	pcs	
MN-63-067	280	420	10	60	909069

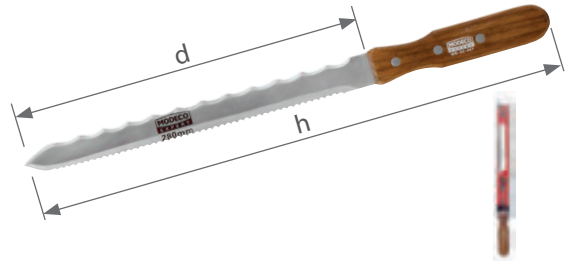

MINERAL WOOL KNIFE



index	d	h			5906675
	mm	mm	pcs	pcs	
MN-63-069	340	480	10	60	377773

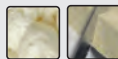

MINERAL WOOL KNIFE

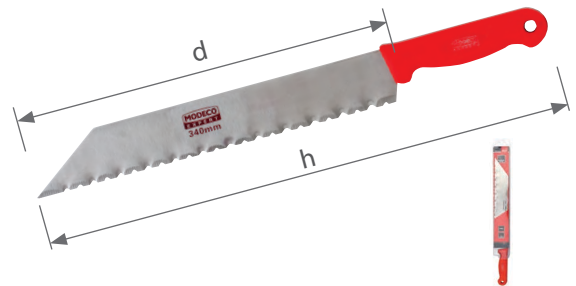

SHEARS

Our flagship product in the family of cutting tools, designed for cutting of metal sheets, steel profiles, metal roofing tiles, etc., is the 250mm long sheet metal shears made of chromium-molybdenum steel.

These are typically used by roofers, electricians, plumbers, and fitters. Their distinguishing feature is the articulated construction which makes cutting easier and requires less force. The automatic jaw lock secures the shears during transport and allows one-handed opening. The two-piece handle improves grip ergonomics and increases comfort of use.

▶ **FORGED JAW MADE OF CRO-MO STEEL WITH HARDNESS OF 56-62 HRC** ensuring extended service life and making it possible to cut sheet metal up to 1.8mm in thickness

▶ **AUTOMATIC JAW LOCK** securing the shears during transport and allowing one-handed opening

◀ **PROFILED JAW** enabling perfect cutting in a straight line and to the left

◀ **ARTICULATED DESIGN** for easier cutting (less force required)

◀ **ERGONOMICALLY PROFILED TWO-COMPONENT HANDLE** for improved comfort of use





index					8590718
	mm	mm	pcs	pcs	
MN-63-214	250	1,8	6	48	730518



JOINT SHEARS FOR METAL SHEET - STRAIGHT SPARTAN





index					8590718
	mm	mm	pcs	pcs	
MN-63-215	250	1,8	6	48	730532



JOINT SHEARS FOR METAL SHEET - LEFT SPARTAN





index					8590718
	mm	mm	pcs	pcs	
MN-63-216	250	1,8	6	48	160124



JOINT SHEARS FOR METAL SHEET - RIGHT SPARTAN



index					5906757
	mm	mm	pcs	pcs	
MN-63-201	250	1,2	6	36	151673



JOINT SHEARS FOR METAL SHEET - RIGHT SPARTAN



index					5906757
	mm	mm	pcs	pcs	
MN-63-202	250	1,2	6	36	151680



JOINT SHEARS FOR METAL SHEET - LEFT SPARTAN



JOINT SHEARS FOR METAL SHEET - STRAIGHT



index					5906757
	mm	mm	pcs	pcs	
MN-63-203	250	1,2	6	36	151697



JOINT SHEARS FOR METAL SHEET - RIGHT



index					5906757
	mm	mm	pcs	pcs	
MN-63-211	250	1,2	6	36	121034



JOINT SHEARS FOR METAL SHEET - LEFT



index					5906757
	mm	mm	pcs	pcs	
MN-63-212	250	1,2	6	36	121041



JOINT SHEARS FOR METAL SHEET



index					5906757
	mm	mm	pcs	pcs	
MN-63-213	250	1,2	6	36	126664





JOINT SHEARS FOR METAL SHEET - STRAIGHT



index					5906757
	mm	mm	pcs	pcs	
MN-63-210	290	1,2	6	36	268562





index				5906757
	mm	pcs	pcs	
MN-63-181	175	6	36	268531
MN-63-182	250	6	36	268548



SHEARS FOR METAL SHEET CLASSIC



index					5906757
	mm	mm	pcs	pcs	
MN-63-185	250	1,2	3	30	270015



SHEARS FOR METAL SHEET - RIGHT CLASSIC



index					5906757
	mm	mm	pcs	pcs	
MN-63-186	250	1,2	3	30	270022



SHEARS FOR METAL SHEET - STRAIGHT CLASSIC







index					5906757
	mm	mm	pcs	pcs	
MN-63-187	300	1,4	3	30	270039



SHEARS FOR METAL SHEET CLASSIC



index					5906757
	mm	mm	pcs	pcs	
MN-63-249	200	3	6	24	161818
MN-63-219	450	6	6	12	146648
MN-63-225	600	8	1	12	146655
MN-63-231	750	10	1	6	146662
MN-63-237	900	12	1	4	157897



Cr-Mo

WIRE SHEARS



RIPPING CHISEL





index				5906757
	mm	pcs	pcs	
MN-67-060	10	6	120	908161
MN-67-062	12	6	60	908178
MN-67-064	14	6	60	908185
MN-67-066	16	6	120	908192
MN-67-068	18	6	60	908208
MN-67-070	20	6	60	908215
MN-67-072	22	6	60	908222
MN-67-075	25	6	60	908239
MN-67-080	30	6	120	908246
MN-67-082	32	6	60	908253





RASP WITH ALUMINIUM BODY



index				5906757
	mm	pcs	pcs	
MN-66-722	250x40	1	18	271401

COLD CHISEL WITH GUARD







index					5906757
	mm	mm	pcs	pcs	
MN-63-481	250	27	6	36	908581
MN-63-482	300	27	6	36	908598
MN-63-484	350	27	6	24	908611



COLD CHISEL WITH GUARD



index					5906757
	mm	mm	pcs	pcs	
MN-63-487	215	100	6	24	908635





PVC TUBE SHEARS



NEW

Available 10.2024

index				5906675
	mm	pcs	pcs	
MN-62-555	0-36	12	72	556109





PVC TUBE SHEARS







MN-62-552

MN-62-551

index				5906675
	mm	pcs	pcs	
MN-62-551	3-42	6	48	393704
MN-62-552	3-42	6	36	393711



index					5906757
	mm	mm	pcs	pcs	
MN-62-570	6-64	22x6	5	20	002326
MN-62-572	50-127	42x11	1	10	002333



PIPE CUTTER



NEW



index					5906757
	mm	mm	pcs	pcs	
MN-62-580	10-60	31x19	1	10	002340



PIPE CUTTER



NEW

index				5906757
	mm	pcs	pcs	
MN-62-577	22x6	1	200	5906675530017
MN-62-578	31x19	1	100	5906757002395
MN-62-579	42x11	1	100	5906757002401





CUTTING WHEELS FOR PIPE CUTTERS







NEW

Available 09.2024

index				5906757
		pcs	pcs	
MN-62-034	M4	1	50	078789
MN-62-035	M5	1	50	078796
MN-62-036	M6	1	50	078802
MN-62-038	M8	1	25	078819
MN-62-040	M10	1	25	078826
MN-62-042	M12	1	25	078833
MN-62-044	M14	1	20	085053
MN-62-046	M16	1	20	079403
MN-62-050	M20	1	20	096806



SCREW TAPS

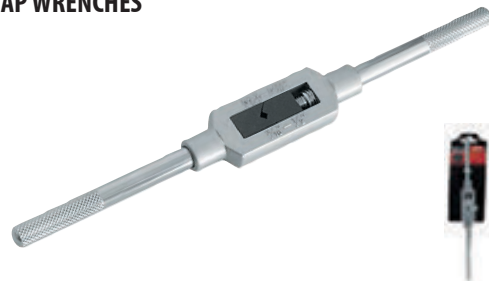

index					5906757
		mm	pcs	pcs	
MN-62-060	M4-M8	200	1	10	139619
MN-62-061	M9-M12	290	1	10	139626
MN-62-062	M13-M18	440	1	10	139633

TAP WRENCHES



index				5906757
		pcs	pcs	
MN-62-136	M6	1	50	079816
MN-62-138	M8	1	30	079823
MN-62-140	M10	1	30	079830
MN-62-142	M12	1	30	079847
MN-62-144	M14	1	25	085671
MN-62-146	M16	1	25	079854
MN-62-150	M20	1	25	110670

DIE NUT



DIE NUT HOLDER



index	ⓘ				5906757	
		mm	pcs	pcs		
MN-62-161	20x7	M4-M6	190	1	10	139671
MN-62-162	25x9	M8	230	1	10	139688
MN-62-163	30x11	M10	255	1	10	139695
MN-62-164	38x14	M12-M14	305	1	10	139701
MN-62-165	45x16	M16	380	1	10	110366

SET OF SCREWTAPERS M3-M12 25 PCS



index	ⓘ			5906757
	części/pieces/шт.	pcs	pcs	
MN-62-308	25	1	60	087682

ⓘ	mm
	M3, M4, M5, M6, M7, M8, M10, M12
	L=200 mm

METAL HAND SAW 300 MM



index				5906757
	mm	pcs	pcs	
MN-65-006	300	6	36	140134



METAL HAND SAW 300MM



index				5906757
	mm	pcs	pcs	
MN-65-010	300	6	36	140127

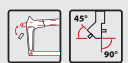



METAL HAND SAW 300





index				5906757
	mm	pcs	pcs	
MN-65-013	300	6	36	908826



index				5906757
	mm	pcs	pcs	
MN-65-143	300	1	100	245600



WOLFRAM BLADES – ROUND



index				5906757
	mm	pcs	pcs	
MN-65-131	300x25	72	720	109940

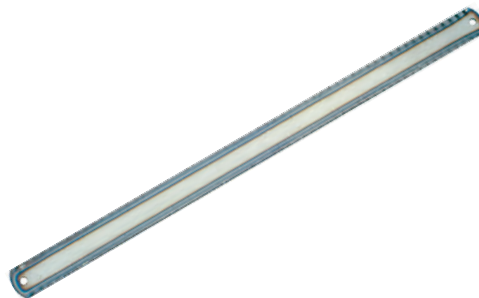

DOUBLE-EDGED BLADE 300X25 MM

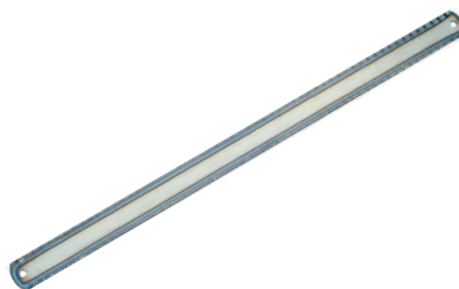

index				5906757
	mm	pcs	pcs	
MN-65-135	300x25	72	720	110779

DOUBLE-EDGED BLADE 300X25 MM





index				5906757
	mm	pcs	pcs	
MN-65-207	155	12	48	271029

DRYWALL SAW 155 MM



hardened 8/1" teeth, thickness 1,5 mm, for cutting plasterboards, wood and PVC



index				5906757
	mm	pcs	pcs	
MN-65-208	300	6	36	903562

DRYWALL SAW 300 MM





for cutting wood, plasterboards and PVC



DRYWALL SAW 550 MM





index				5906757
	mm	pcs	pcs	
MN-65-511	550	6	24	902596



hardened teeth teflon coating, for cutting wood, PVC and plasterboards

TENON SAW 300 MM





index				5906757
	mm	pcs	pcs	
MN-65-413	300	6	24	266537



hardened 14/1" teeth, for cutting wood, plywood and panels

HAND SAWS GOLD LINE





index				5906757
	mm	pcs	pcs	
MN-65-522	400	6	24	270053
MN-65-523	450	6	24	270060
MN-65-524	500	6	24	270077
MN-65-525	550	6	24	270084



hardened 9/1" teeth
FRIENDLY GRIP
thickness 1 mm, for cutting wood, plywood and panels

ONE-SIDED NARROW BLADE





index				5906757
	mm	pcs	pcs	
MN-65-526	400	10	60	157262
MN-65-528	450	10	60	157279
MN-65-530	500	10	60	157286



hardened 9/1" teeth
thickness 1 mm, for cutting wood, plywood and panels. screw fixed blade





HAND SAWS BLACK SHARK



index				5906757
	mm	pcs	pcs	
MN-65-542	400	10	60	908833
MN-65-543	450	10	60	908840
MN-65-544	500	10	60	908857



hardened 8/1" teeth
FRIENDLY GRIP
thickness 1 mm, for cutting wood, plywood and panels

index					5906757
	mm	widias/teeth	pcs	pcs	
MN-65-640	700	17/34	6	12	273139





zęby HM, uchwyt Friendly Grip, do cięcia pustaków i ceramiki

HM teeth, FRIENDLY GRIP, for cutting hollow tiles and ceramics

зубья HM, ручка Friendly Grip, для резки пустотелых блоков и керамики

CELLULAR CONCRETE SAW 700 MM GOLD LINE





index				5906757
	mm	pcs	pcs	
MN-65-220	530	12	24	265721
MN-65-224	600	1	12	265745
MN-65-230	760	1	12	265752





FRAME SAWS



index				5906757
	mm	pcs	pcs	
MN-65-250	530	20	200	265776
MN-65-254	600	20	200	265783
MN-65-260	760	20	200	265790

FRAME SAW BLADES



index	rows			5906757
		pcs	pcs	
MN-69-013	3	10	10	150867
MN-69-014	4	10	10	150874
MN-69-015	5	10	10	150881
MN-69-016	6	10	10	154810



WIRE BRUSHES



LIST OF INDEXES

Index	Page	Index	Page	Index	Page	Index	Page	Index	Page	Index	Page
MN-02-460	161	MN-05-140	159	MN-10-107	83	MN-15-511	51	MN-20-184	93	MN-25-418	101
MN-02-475	161	MN-05-142	159	MN-10-151	82	MN-15-512	51	MN-20-187	93	MN-25-424	101
MN-02-490	161	MN-05-144	159	MN-10-152	82	MN-15-514	52	MN-20-189	93	MN-26-016	99
MN-02-503	127	MN-05-232	159	MN-10-153	82	MN-15-515	52	MN-20-191	94	MN-26-017	99
MN-02-506	127	MN-05-234	159	MN-10-154	82	MN-15-521	52	MN-20-192	94	MN-26-018	99
MN-02-508	127	MN-05-236	159	MN-10-157	82	MN-15-522	52	MN-20-205	97	MN-26-020	92
MN-02-510	127	MN-05-238	159	MN-10-159	82	MN-15-540	53	MN-20-226	94	MN-26-023	92
MN-02-512	127	MN-05-250	159	MN-10-160	82	MN-15-541	53	MN-20-265	97	MN-26-025	92
MN-02-612	127	MN-05-252	159	MN-10-161	82	MN-15-542	53	MN-20-305	98	MN-26-027	92
MN-02-613	127	MN-05-330	159	MN-10-162	82	MN-16-006B	54	MN-20-326	94	MN-26-066	99
MN-02-615	127	MN-05-332	159	MN-10-163	82	MN-16-007	53	MN-20-505	98	MN-26-067	99
MN-02-621	127	MN-05-334	159	MN-10-165	82	MN-16-008	53	MN-20-526	95	MN-26-076	98
MN-02-622	127	MN-05-340	160	MN-10-168	82	MN-16-008B	54	MN-20-607	98	MN-26-077	98
MN-02-623	127	MN-05-350	160	MN-10-171	82	MN-16-010	53	MN-20-610	98	MN-26-120	99
MN-02-624	127	MN-05-351	160	MN-10-172	82	MN-16-010B	54	MN-20-612	98	MN-26-121	99
MN-02-626	127	MN-05-352	160	MN-10-173	82	MN-16-013	53	MN-20-620	95	MN-26-122	99
MN-02-632	127	MN-05-353	160	MN-10-175	82	MN-16-013B	54	MN-20-640	95	MN-26-123	99
MN-02-633	127	MN-05-605	160	MN-10-200	83	MN-16-105	54	MN-20-641	95	MN-26-140	99
MN-02-634	127	MN-05-640	160	MN-10-551	86	MN-16-205	54	MN-20-642	95	MN-26-141	99
MN-02-635	127	MN-05-641	160	MN-10-552	86	MN-16-207	54	MN-20-651	90	MN-26-142	99
MN-02-636	127	MN-06-109	167	MN-10-553	86	MN-16-208	54	MN-20-660	95	MN-26-218	99
MN-02-643	127	MN-06-132	167	MN-10-554	86	MN-16-215	55	MN-20-706	95	MN-30-402	105
MN-02-644	127	MN-06-140-2	167	MN-10-561	86	MN-17-050	87	MN-20-708	95	MN-30-403	105
MN-02-645	127	MN-06-143-1	166	MN-10-562	86	MN-17-140	87	MN-20-710	95	MN-30-404	105
MN-02-646	127	MN-06-143-2	166	MN-10-563	86	MN-17-190	87	MN-20-716	96	MN-30-405	105
MN-03-110	171	MN-06-143-3	166	MN-10-570	86	MN-17-200	87	MN-20-718	96	MN-30-408	105
MN-03-112	171	MN-06-144-1	167	MN-10-571	86	MN-17-240	87	MN-20-720	96	MN-30-410	105
MN-03-170	170	MN-06-144-2	167	MN-10-572	86	MN-17-240/1	87	MN-20-726	96	MN-30-415	105
MN-03-171	170	MN-06-144-3	167	MN-10-573	86	MN-17-290	87	MN-20-728	96	MN-30-420	105
MN-03-172	170	MN-06-145-1	166	MN-10-580	86	MN-17-290/1	87	MN-20-730	96	MN-30-603	105
MN-03-173	170	MN-06-150/10	164	MN-10-581	86	MN-17-300	88	MN-20-736	96	MN-30-605	105
MN-03-174	170	MN-06-150/9	164	MN-10-582	86	MN-17-302	88	MN-20-738	96	MN-30-608	105
MN-03-175	171	MN-06-164/9	165	MN-11-070	86	MN-17-305	88	MN-20-740	96	MN-30-610	105
MN-03-176	171	MN-06-171/11	165	MN-11-081	82	MN-17-307	88	MN-22-008	100	MN-30-615	105
MN-03-218	172	MN-06-205	168	MN-11-082	82	MN-19-010	54	MN-22-011	100	MN-30-620	105
MN-03-219	172	MN-06-210	165	MN-13-004	83	MN-20-005	96	MN-22-012	100	MN-31-212	106
MN-03-220	172	MN-06-212	165	MN-13-007	83	MN-20-026	94	MN-22-014	100	MN-31-216	106
MN-03-401	173	MN-06-212/9	165	MN-13-009	83	MN-20-027	94	MN-22-018	100	MN-31-224	106
MN-03-406	173	MN-06-214	165	MN-13-014	83	MN-20-028	94	MN-23-057	90	MN-31-232	106
MN-03-416	173	MN-06-214/9	165	MN-13-017	83	MN-20-080	89	MN-23-060	91	MN-32-001	104
MN-03-421	173	MN-06-216	166	MN-14-205	84	MN-20-081	89	MN-23-062	91	MN-32-007	104
MN-03-422	173	MN-06-216/9	166	MN-14-206	84	MN-20-082	89	MN-23-064	91	MN-32-008	104
MN-03-426	174	MN-06-218	166	MN-14-207	84	MN-20-086	90	MN-23-066	91	MN-32-012	105
MN-03-427	174	MN-06-218/9	166	MN-14-210	88	MN-20-087	90	MN-23-068	92	MN-32-013	104
MN-03-451	174	MN-06-220	166	MN-15-152	52	MN-20-088	90	MN-23-079	91	MN-32-017	105
MN-03-452	174	MN-06-220/9	166	MN-15-152-2	53	MN-20-089	90	MN-25-101	101	MN-32-018	104
MN-03-460	26	MN-06-303	168	MN-15-302	50	MN-20-092	89	MN-25-102	101	MN-32-022	105
MN-03-460	171	MN-06-306	168	MN-15-312	50	MN-20-094	89	MN-25-103	101	MN-32-103	106
MN-03-464	26	MN-06-307	168	MN-15-391	50	MN-20-096	89	MN-25-110	101	MN-33-005	106
MN-03-464	172	MN-06-610	167	MN-15-393	51	MN-20-098	89	MN-25-111	101	MN-35-214	107
MN-03-466	26	MN-06-611	167	MN-15-394	51	MN-20-100	93	MN-25-112	101	MN-35-215	107
MN-03-466	172	MN-06-612	167	MN-15-395	51	MN-20-105	97	MN-25-113	101	MN-35-216	107
MN-05-006	160	MN-06-621	167	MN-15-396	51	MN-20-126	94	MN-25-115	101	MN-35-400	107
MN-05-008	160	MN-09-080	127	MN-15-398	51	MN-20-127	94	MN-25-200	100	MN-37-200	107
MN-05-009	160	MN-09-083	128	MN-15-402	50	MN-20-146	98	MN-25-220	101	MN-37-201	107
MN-05-010	160	MN-09-092	128	MN-15-412	50	MN-20-147	98	MN-25-410	101	MN-37-230	107
MN-05-136	159	MN-09-095	128	MN-15-501	51	MN-20-165	97	MN-25-412	101	MN-37-243	107
MN-05-138	159	MN-09-096	128	MN-15-502	51	MN-20-180	93	MN-25-414	101	MN-37-245	107

Index	Page	Index	Page	Index	Page	Index	Page	Index	Page	Index	Page
MN-37-248	107	MN-51-409	118	MN-59-615	119	MN-61-145	61	MN-61-630	59	MN-61-962	63
MN-37-250	107	MN-51-410	118	MN-59-616	119	MN-61-147	61	MN-61-632	59	MN-61-963	63
MN-37-255	107	MN-51-411	118	MN-59-617	119	MN-61-148	61	MN-61-635	59	MN-61-964	63
MN-37-260	107	MN-51-412	118	MN-59-618	119	MN-61-152	61	MN-61-640	59	MN-61-965	63
MN-37-262	107	MN-51-413	118	MN-59-619	119	MN-61-153	61	MN-61-678	60	MN-61-966	63
MN-37-263	107	MN-51-414	118	MN-59-657	120	MN-61-154	62	MN-61-680	60	MN-61-967	63
MN-37-264	107	MN-51-415	118	MN-59-710	119	MN-61-155	62	MN-61-753	60	MN-61-968	63
MN-37-265	107	MN-51-416	118	MN-59-713	119	MN-61-157	62	MN-61-756	60	MN-61-969	63
MN-37-266	107	MN-51-417	118	MN-59-717	119	MN-61-158	62	MN-61-760	60	MN-62-034	187
MN-37-270	107	MN-51-418	118	MN-59-719	119	MN-61-163	62	MN-61-801	59	MN-62-035	187
MN-37-353	107	MN-51-419	118	MN-59-757	120	MN-61-165	62	MN-61-802	59	MN-62-036	187
MN-37-354	107	MN-51-421	118	MN-60-230	57	MN-61-167	62	MN-61-902	63	MN-62-038	187
MN-37-356	107	MN-51-422	118	MN-60-240	57	MN-61-168	62	MN-61-903	63	MN-62-040	187
MN-37-359	107	MN-51-424	118	MN-60-250	57	MN-61-175	62	MN-61-904	63	MN-62-042	187
MN-40-006	112	MN-51-427	118	MN-60-260	57	MN-61-177	62	MN-61-905	63	MN-62-044	187
MN-40-007	112	MN-51-430	118	MN-60-265	57	MN-61-178	62	MN-61-906	63	MN-62-046	187
MN-40-017	112	MN-51-432	118	MN-60-270	57	MN-61-187	62	MN-61-907	63	MN-62-050	187
MN-40-018	112	MN-53-100	124	MN-60-280	57	MN-61-197	62	MN-61-908	63	MN-62-060	187
MN-40-020	113	MN-53-106	124	MN-60-300	57	MN-61-202	62	MN-61-909	63	MN-62-061	187
MN-40-023	113	MN-53-108	124	MN-60-310	57	MN-61-204	60	MN-61-910	63	MN-62-062	187
MN-40-025	113	MN-53-110	124	MN-60-320	57	MN-61-205	60	MN-61-911	63	MN-62-136	187
MN-40-110	112	MN-53-112	124	MN-60-904	57	MN-61-206	60	MN-61-912	63	MN-62-138	187
MN-40-305	113	MN-53-130	124	MN-60-906	57	MN-61-208	60	MN-61-913	63	MN-62-140	187
MN-40-310	113	MN-54-102	125	MN-60-911	57	MN-61-210	60	MN-61-914	63	MN-62-142	187
MN-45-100	111	MN-54-106	126	MN-60-931	57	MN-61-212	60	MN-61-915	63	MN-62-144	187
MN-45-109	111	MN-54-116	126	MN-60-932	58	MN-61-240	64	MN-61-916	63	MN-62-146	187
MN-45-110	111	MN-54-117	125	MN-60-933	58	MN-61-241	64	MN-61-917	63	MN-62-150	187
MN-45-120	111	MN-54-118	125	MN-60-934	58	MN-61-246	65	MN-61-918	63	MN-62-161	188
MN-46-106	111	MN-54-119	125	MN-61-054	61	MN-61-266	65	MN-61-919	63	MN-62-162	188
MN-46-108	111	MN-54-120	126	MN-61-056	61	MN-61-281	65	MN-61-920	63	MN-62-163	188
MN-46-110	111	MN-54-121	125	MN-61-057	61	MN-61-366	65	MN-61-921	63	MN-62-164	188
MN-46-112	111	MN-54-131	126	MN-61-064	61	MN-61-381	65	MN-61-922	63	MN-62-165	188
MN-46-114	111	MN-54-132	126	MN-61-065	61	MN-61-395	66	MN-61-923	63	MN-62-308	188
MN-46-146	111	MN-54-134	127	MN-61-070	61	MN-61-406	66	MN-61-924	63	MN-62-390	55
MN-46-148	111	MN-55-507	121	MN-61-071	61	MN-61-408	66	MN-61-925	63	MN-62-551	186
MN-46-150	111	MN-55-517	121	MN-61-076	61	MN-61-411	66	MN-61-926	63	MN-62-552	186
MN-46-152	111	MN-55-519	121	MN-61-077	61	MN-61-413	66	MN-61-927	63	MN-62-555	186
MN-46-154	111	MN-55-520	121	MN-61-091	62	MN-61-417	66	MN-61-928	63	MN-62-570	187
MN-50-236	117	MN-55-551	120	MN-61-092	62	MN-61-420	66	MN-61-929	63	MN-62-572	187
MN-50-238	117	MN-55-552	120	MN-61-093	62	MN-61-423	66	MN-61-930	63	MN-62-577	187
MN-50-240	117	MN-55-555	121	MN-61-094	62	MN-61-427	66	MN-61-931	63	MN-62-578	187
MN-50-413	117	MN-55-557	120	MN-61-106	61	MN-61-434	66	MN-61-932	63	MN-62-579	187
MN-50-422	117	MN-56-010	121	MN-61-109	61	MN-61-452	66	MN-61-933	63	MN-62-580	187
MN-50-428	117	MN-57-151	122	MN-61-116	61	MN-61-454	66	MN-61-934	63	MN-62-590	101
MN-50-440	117	MN-57-152	122	MN-61-117	61	MN-61-504	59	MN-61-937	63	MN-62-592	102
MN-50-449	117	MN-57-153	122	MN-61-121	61	MN-61-505	59	MN-61-938	63	MN-62-600	102
MN-50-453	117	MN-57-154	122	MN-61-122	61	MN-61-506	59	MN-61-950	63	MN-62-601	102
MN-50-456	117	MN-57-318	123	MN-61-123	61	MN-61-508	59	MN-61-951	63	MN-63-011	178
MN-50-458	117	MN-57-320	123	MN-61-124	61	MN-61-510	59	MN-61-952	63	MN-63-021	178
MN-50-462	117	MN-57-323	124	MN-61-131	61	MN-61-512	59	MN-61-953	63	MN-63-026	178
MN-51-236	118	MN-59-001	124	MN-61-132	61	MN-61-571	59	MN-61-954	63	MN-63-027	178
MN-51-238	118	MN-59-608	119	MN-61-133	61	MN-61-572	59	MN-61-955	63	MN-63-034	178
MN-51-242	118	MN-59-609	119	MN-61-134	61	MN-61-616	59	MN-61-956	63	MN-63-039	179
MN-51-250	119	MN-59-610	119	MN-61-137	61	MN-61-618	59	MN-61-957	63	MN-63-040	179
MN-51-255	119	MN-59-611	119	MN-61-141	61	MN-61-620	59	MN-61-958	63	MN-63-041	179
MN-51-406	118	MN-59-612	119	MN-61-142	61	MN-61-622	59	MN-61-959	63	MN-63-042	179
MN-51-407	118	MN-59-613	119	MN-61-143	61	MN-61-625	59	MN-61-960	63	MN-63-055	90
MN-51-408	118	MN-59-614	119	MN-61-144	61	MN-61-628	59	MN-61-961	63	MN-63-056	90

LIST OF INDEXES

Index	Page	Index	Page	Index	Page	Index	Page	Index	Page	Index	Page
MN-63-067	181	MN-65-165	67	MN-67-080	186	MN-68-815	73	MN-70-504	141	MN-72-530	144
MN-63-069	181	MN-65-166	67	MN-67-082	186	MN-68-821	73	MN-70-506	141	MN-72-542	145
MN-63-121	179	MN-65-167	67	MN-68-460/5	70	MN-68-822	73	MN-70-508	141	MN-72-544	145
MN-63-124	180	MN-65-168	67	MN-68-461/5	70	MN-68-823	73	MN-70-510	141	MN-72-546	145
MN-63-125	180	MN-65-169	67	MN-68-462/5	70	MN-68-824	73	MN-70-512	141	MN-72-548	145
MN-63-126	180	MN-65-170	67	MN-68-463/5	70	MN-68-825	73	MN-70-515	141	MN-72-550	145
MN-63-127	180	MN-65-182	67	MN-68-464/5	70	MN-68-831	73	MN-70-520	141	MN-72-580	145
MN-63-130	180	MN-65-183	67	MN-68-465/5	70	MN-68-832	73	MN-70-536	141	MN-72-581	145
MN-63-131	180	MN-65-184	67	MN-68-466/5	70	MN-68-833	73	MN-70-538	141	MN-73-040	142
MN-63-133	180	MN-65-185	67	MN-68-467/5	70	MN-68-834	73	MN-70-540	141	MN-73-041	142
MN-63-137	180	MN-65-186	68	MN-68-468/5	70	MN-68-835	73	MN-70-542	141	MN-73-042	142
MN-63-181	185	MN-65-187	68	MN-68-469/5	70	MN-68-841	73	MN-70-545	141	MN-73-043	142
MN-63-182	185	MN-65-188	68	MN-68-470	70	MN-68-842	73	MN-70-550	141	MN-73-044	142
MN-63-185	185	MN-65-189	68	MN-68-470/5	70	MN-68-843	73	MN-70-556	141	MN-73-045	142
MN-63-186	185	MN-65-190	68	MN-68-473	70	MN-68-844	73	MN-70-558	141	MN-73-046	142
MN-63-187	185	MN-65-191	68	MN-68-473/5	70	MN-68-845	73	MN-70-560	141	MN-73-047	142
MN-63-201	183	MN-65-192	68	MN-68-476	70	MN-68-902	72	MN-70-562	141	MN-73-050	143
MN-63-202	183	MN-65-193	68	MN-68-476/5	70	MN-68-905	72	MN-70-565	141	MN-73-051	143
MN-63-203	184	MN-65-194	68	MN-68-479	70	MN-68-907	72	MN-70-570	141	MN-73-052	143
MN-63-210	184	MN-65-195	68	MN-68-479/5	70	MN-68-908	72	MN-71-122	141	MN-73-053	143
MN-63-211	184	MN-65-196	68	MN-68-482	70	MN-68-909	72	MN-71-127	141	MN-73-054	143
MN-63-212	184	MN-65-197	68	MN-68-482/5	70	MN-68-911	72	MN-71-130	141	MN-73-055	143
MN-63-213	184	MN-65-198	68	MN-68-485	70	MN-68-912	72	MN-71-223	142	MN-73-060	143
MN-63-214	183	MN-65-199	68	MN-68-488	70	MN-68-915	72	MN-71-227	142	MN-73-061	143
MN-63-215	183	MN-65-200	68	MN-68-488/5	70	MN-68-916	72	MN-71-232	142	MN-73-062	143
MN-63-216	183	MN-65-201	68	MN-68-491	70	MN-68-917	72	MN-71-317	142	MN-73-063	143
MN-63-219	185	MN-65-207	189	MN-68-540/5	69	MN-68-922	73	MN-71-322	142	MN-73-064	143
MN-63-225	185	MN-65-208	189	MN-68-541/5	69	MN-68-925	73	MN-71-327	142	MN-73-065	143
MN-63-231	185	MN-65-220	191	MN-68-542/5	69	MN-68-932	73	MN-71-802	164	MN-73-066	143
MN-63-237	185	MN-65-224	191	MN-68-543/5	69	MN-68-935	73	MN-71-803	164	MN-73-067	143
MN-63-249	185	MN-65-230	191	MN-68-544/5	69	MN-68-942	73	MN-71-804	164	MN-73-102	150
MN-63-327	181	MN-65-250	191	MN-68-545/5	69	MN-68-945	73	MN-71-804-A	164	MN-73-107	151
MN-63-328	181	MN-65-254	191	MN-68-546/5	69	MN-68-961	72	MN-72-076	143	MN-73-115	151
MN-63-329	181	MN-65-260	191	MN-68-547/5	69	MN-68-962	72	MN-72-078	143	MN-73-130	151
MN-63-481	186	MN-65-413	190	MN-68-548/5	69	MN-68-965	72	MN-72-080	143	MN-73-160	151
MN-63-482	186	MN-65-511	190	MN-68-549/5	69	MN-68-966	72	MN-72-100	143	MN-73-162	151
MN-63-484	186	MN-65-522	190	MN-68-550/5	69	MN-68-967	72	MN-72-130	143	MN-73-165	152
MN-63-487	186	MN-65-523	190	MN-68-551/5	69	MN-69-013	191	MN-72-131	143	MN-73-178	152
MN-64-027	106	MN-65-524	190	MN-68-552/5	69	MN-69-014	191	MN-72-132	143	MN-73-182	152
MN-64-029	106	MN-65-525	190	MN-68-553/5	69	MN-69-015	191	MN-72-133	143	MN-73-185	152
MN-64-090	106	MN-65-526	190	MN-68-554/5	69	MN-69-016	191	MN-72-134	143	MN-73-193	152
MN-64-092	106	MN-65-528	190	MN-68-555/5	69	MN-69-112	77	MN-72-135	143	MN-73-194	152
MN-64-094	106	MN-65-530	190	MN-68-605	71	MN-69-114	77	MN-72-136	144	MN-73-260	149
MN-64-096	106	MN-65-542	190	MN-68-606	71	MN-69-121	77	MN-72-370	144	MN-73-330	150
MN-64-206	106	MN-65-543	190	MN-68-608	72	MN-69-122	77	MN-72-371	144	MN-73-336	150
MN-64-208	106	MN-65-544	190	MN-68-609	71	MN-69-134	78	MN-72-372	144	MN-73-338	150
MN-64-210	106	MN-65-621	66	MN-68-611	71	MN-69-135	78	MN-72-373	144	MN-73-339	150
MN-64-212	106	MN-65-622	66	MN-68-620	70	MN-69-142	76	MN-72-374	144	MN-73-340	150
MN-64-215	106	MN-65-640	191	MN-68-622	70	MN-69-144	76	MN-72-375	144	MN-73-341	150
MN-64-218	106	MN-66-722	186	MN-68-624	71	MN-69-164	77	MN-72-502	144	MN-73-370	149
MN-65-006	188	MN-67-060	186	MN-68-801	69	MN-69-165	77	MN-72-504	144	MN-73-371	150
MN-65-010	188	MN-67-062	186	MN-68-803	69	MN-69-172	77	MN-72-506	144	MN-73-380	149
MN-65-013	188	MN-67-064	186	MN-68-804	69	MN-69-173	77	MN-72-508	144	MN-73-386	149
MN-65-131	189	MN-67-066	186	MN-68-806	69	MN-69-175	77	MN-72-510	144	MN-73-388	149
MN-65-135	189	MN-67-068	186	MN-68-811	73	MN-69-191	77	MN-72-522	144	MN-73-390	149
MN-65-143	189	MN-67-070	186	MN-68-812	73	MN-69-193	77	MN-72-524	144	MN-73-395	149
MN-65-148	153	MN-67-072	186	MN-68-813	73	MN-69-200	102	MN-72-526	144	MN-73-400	149
MN-65-164	67	MN-67-075	186	MN-68-814	73	MN-70-502	141	MN-72-528	144	MN-73-406	149

Index	Page	Index	Page	Index	Page	Index	Page	Index	Page	Index	Page
MN-73-408	149	MN-76-123	65	MN-79-011	156	MN-81-133	134	MN-88-090/T	158	MN-93-215	41
MN-73-410	149	MN-76-124	65	MN-79-012	156	MN-81-135	134	MN-88-091	158	MN-93-220	32
MN-73-420	149	MN-76-125	65	MN-79-013	156	MN-81-137	134	MN-88-091/T	158	MN-93-225	32
MN-73-421	150	MN-76-126	65	MN-79-018	157	MN-81-143	134	MN-88-100	158	MN-93-307	42
MN-74-160	146	MN-76-127	65	MN-79-032	157	MN-81-145	134	MN-88-100/T	158	MN-94-008	35
MN-74-163	146	MN-76-128	65	MN-79-061	75	MN-81-148	134	MN-88-101	158	MN-94-010	35
MN-74-164	146	MN-76-130	154	MN-79-063	75	MN-81-152	134	MN-88-101/T	158	MN-94-151	42
MN-74-197	146	MN-76-206	63	MN-79-069	75	MN-81-153	134	MN-90-031	13	MN-94-152	43
MN-74-198	146	MN-76-208	63	MN-79-071	75	MN-81-155	134	MN-90-032	13	MN-94-153	32
MN-74-199	146	MN-76-210	63	MN-79-073	75	MN-81-156	134	MN-90-033	13	MN-94-153	43
MN-74-208	147	MN-76-212	63	MN-79-074	75	MN-81-158	134	MN-90-034	14	MN-94-190	79
MN-74-209	147	MN-76-225	63	MN-79-075	76	MN-81-183	134	MN-90-035	14	MN-94-192	79
MN-74-210	145	MN-76-235	63	MN-79-076	76	MN-81-185	134	MN-90-104	14	MN-94-193	79
MN-74-211	145	MN-76-245	63	MN-79-077	76	MN-81-186	134	MN-90-105	15	MN-94-194	79
MN-74-212	145	MN-76-255	63	MN-79-078	76	MN-81-188	134	MN-90-107	15	MN-94-196	79
MN-74-218	146	MN-76-268	63	MN-79-079	76	MN-81-203	135	MN-90-211	17	MN-94-197	79
MN-74-219	146	MN-76-290	64	MN-79-080	75	MN-81-205	135	MN-90-221	17	MN-94-198	79
MN-74-220	146	MN-76-294	64	MN-79-081	75	MN-81-208	135	MN-90-222	17	MN-94-199	79
MN-74-221	146	MN-76-298	64	MN-79-082	75	MN-81-211	135	MN-90-223	18	MN-94-200	79
MN-74-303	147	MN-76-306	64	MN-79-083	75	MN-81-221	135	MN-90-252	18	MN-94-201	79
MN-74-304	147	MN-76-308	64	MN-79-089	76	MN-81-231	135	MN-91-130	20	MN-94-202	79
MN-74-305	147	MN-76-310	64	MN-79-093	76	MN-81-232	135	MN-91-131	20	MN-94-203	79
MN-74-318	145	MN-76-312	64	MN-79-095	76	MN-81-252	135	MN-91-132	21	MN-95-005	46
MN-74-320	145	MN-76-315	64	MN-79-096	76	MN-83-020	135	MN-91-133	21	MN-95-006	46
MN-74-328	146	MN-76-316	64	MN-79-100	161	MN-83-022	135	MN-91-134	21	MN-97-043	67
MN-75-071	153	MN-76-317	64	MN-79-161	161	MN-83-024	135	MN-91-135	21	MN-97-904	78
MN-75-242	153	MN-76-318	64	MN-79-162	161	MN-83-026	135	MN-91-136	22	MN-97-906	78
MN-75-243	153	MN-76-320	154	MN-79-163	161	MN-83-030	135	MN-91-137	22	MN-97-909	78
MN-75-246	153	MN-76-322	154	MN-79-164	161	MN-83-040	136	MN-91-138	22	MN-97-960	78
MN-75-247	153	MN-76-324	154	MN-79-165	161	MN-83-042	136	MN-91-139	23	MN-97-980-1	78
MN-75-286	153	MN-76-326	154	MN-79-221	153	MN-83-050	136	MN-91-140	23	MN-97-980-5	78
MN-75-288	153	MN-76-440	155	MN-79-355	161	MN-83-055	136	MN-91-141	24	MN-97-980-B	78
MN-75-290	153	MN-76-442	155	MN-79-356	161	MN-83-057	136	MN-91-142	24	MN-97-993-1	78
MN-75-502	153	MN-76-444	155	MN-79-357	162	MN-83-060	142	MN-91-143	24	MN-97-993-5	78
MN-75-503	153	MN-76-448	155	MN-79-358	162	MN-83-062	142	MN-91-144	25	MN-97-993-B	78
MN-75-504	153	MN-76-450	155	MN-79-360	162	MN-83-068	142	MN-91-146	25	MN-97-994-1	79
MN-75-511	153	MN-76-452	155	MN-79-365	163	MN-83-100	136	MN-91-147	25	MN-97-994-5	79
MN-76-000	155	MN-76-456	155	MN-79-370	163	MN-83-102	136	MN-91-148	23	MN-97-994-B	79
MN-76-000/C	155	MN-76-458	155	MN-79-375	163	MN-85-100	137	MN-91-501	20	MN-97-995-1	79
MN-76-001	155	MN-76-460	155	MN-79-400	163	MN-85-101	137	MN-92-014	39	MN-97-995-5	79
MN-76-001/C	155	MN-76-464	155	MN-79-401	163	MN-88-015	157	MN-92-015	39	MN-97-995-B	79
MN-76-002	155	MN-76-466	155	MN-79-402	164	MN-88-018	157	MN-92-091	41	MN-97-996-1	79
MN-76-002/C	155	MN-76-468	155	MN-79-403	164	MN-88-022	157	MN-92-101	39	MN-97-996-5	79
MN-76-003	155	MN-76-470	155	MN-79-405	162	MN-88-026	157	MN-92-102	40	MN-97-996-B	79
MN-76-003/C	155	MN-76-473	155	MN-79-406	162	MN-88-032	157	MN-92-103	40	MN-97-997-1	79
MN-76-004	155	MN-78-132	74	MN-80-151	133	MN-88-033	157	MN-92-207	42	MN-97-997-5	79
MN-76-005	155	MN-78-133	74	MN-80-152	133	MN-88-034	157	MN-92-304	33	MN-97-997-B	79
MN-76-010	156	MN-78-135	74	MN-80-162	133	MN-88-035	157	MN-92-501	40	MN-99-003	36
MN-76-011	156	MN-78-212	74	MN-80-171	133	MN-88-036	157	MN-93-011	30	MN-99-005	36
MN-76-011/C	155	MN-78-213	74	MN-80-172	133	MN-88-080	158	MN-93-015	45	MN-99-006	36
MN-76-013	156	MN-78-215	74	MN-80-212	133	MN-88-080/T	158	MN-93-016	45	MN-99-206	37
MN-76-014	156	MN-78-220	74	MN-81-023	133	MN-88-081	158	MN-93-022	29	MN-99-207	37
MN-76-016	155	MN-78-312	74	MN-81-025	133	MN-88-081/T	158	MN-93-035	28	MN-99-922	46
MN-76-016/C	155	MN-78-313	74	MN-81-028	133	MN-88-082	158	MN-93-036	28		
MN-76-017/C	155	MN-78-315	74	MN-81-030	133	MN-88-082/T	158	MN-93-037	28		
MN-76-104	65	MN-78-411	74	MN-81-113	134	MN-88-083	158	MN-93-038	29		
MN-76-120	65	MN-78-412	75	MN-81-115	134	MN-88-083/T	158	MN-93-039	30		
MN-76-122	65	MN-78-413	75	MN-81-132	134	MN-88-090	158	MN-93-210	41		

MODECO EXPERT

AUSTRALIA

Rawlplug Australia
255 Whitehorse Road
Suite 7, Level 1
Balwyn, Vic 3103
Tel: + 61 428 647 745
Email: craig.salmon@rawlplug.com
Web: www.rawlplug.com

GERMANY

Koelner Deutschland GmbH
Gmünder Str. 65
73614 Schorndorf
Tel: +49 (0) 7181 977 72-0
Email: info@koelner-befestigung.de
Web: www.rawlplug.com

ITALY

Rawlplug Italy S.r.l.
Via Privata Euro Industrie n. 4/6
20052 - Vignate (MI)
Tel. +39 02 50309590
Email: informazioni@rawlplug.com
Web: www.rawlplug.it

REPUBLIC OF SOUTH AFRICA

Rawl Africa (Pty) Ltd
Cargo Village, 9 Sim Road, Pomona,
Kempton Park, 1619,
Tel: +27 10 492 3379
Email: africa@rawlplug.com
Web: rawlplug.co.za

SPAIN

Rawlplug España SL
Calle Ronda de Don Bosco 41,
oficina 13
36202 Vigo (Pontevedra)
Email: es.clientes@rawlplug.com
Tel. +34 653 782 215
Web: www.rawlplug.es

UKRAINE

Koelner Ukraine LLC
Lvivska Bichna, 6
Sokilnyky
Pustomyty Dstr., Lviv Reg. 81130
Tel.: + 380 (32) 2440 744
Email: koelner@koelner.ua
Web: www.koelner.ua

VIETNAM

**Factory A_18_4_B, C, D, E,
Lot A_18_CN**
Bau Bang Industrial Park, Lai Uyen Town
Bau Bang District,
Binh Duong Province
Vietnam, 75700
Email: info@rawlplug.com

CHINA

**Rawlplug Shanghai
Trading Co., Ltd.**
Room B209, No. 139 Fanghua Road,
Pudong, Shanghai
P.R. China Post code 201204
Tel:+86 189 1882 8527
Email: Jennifer.Song@rawlplug.com
Web: www.rawlplug.com

HUNGARY

Koelner Hungária Kft
Jedlik Ányos út. 34
2330 Dunaharaszti
Tel: + 36 (24) 520 400
Email: info@koelner.hu
Web: www.koelner.hu

LITHUANIA

UAB Koelner Vilnius
Žarijų g. 2
LT-02300, Vilnius
Tel: + 370 (5) 2324 862
Email: koelner@koelner.lt
Web: www.koelner.lt

RUSSIA

Koelner Trading KLD LLC
ul. Dzerzhinskogo 219
236034 Kaliningrad
Tel: + 7 (4012)65 85 75
Email: info@koelner-trading.ru
Web: www.koelner-trading.ru

SWEDEN

Rawl Scandinavia AB
Baumansgatan 4
593 32 Västervik
Tel: +46(0)490 30660
Email: info@rawlplug.se
Web: www.rawlplug.se

UNITED ARAB EMIRATES

Rawlplug Middle East FZE
P.O. Box 261024 Dubai, UAE
Warehouse No.RA08BC01
Tel: + 971 (4) 8839 501
Email: dubai@rawlplug.co.uk
Web: www.rawl.ae

CZECH REPUBLIC

Rawlplug CZ s. r. o.
Palackého 1154/76A
702 00 Ostrava-Prívov
Tel: + 420 596 636A 397
Email: objednavky.cz@rawlplug.com
Web: www.rawlplug.cz

INDIA

**BANGALORE OFFICE
Rawlplug Products and Services
India Private Limited**
29,Prestige Meridien-1, 505-506, M.G.Road,
Bangalore – 560001, Karnataka, India
Tel: +91 80 43022234
Email: india@rawlplug.com
Web: rawlplug.com

POLAND

Rawlplug S.A.
ul. Kwidzińska 6
51-416 Wrocław
Tel. +48 (71) 32 60 100
Fax. +48 (71) 37 26 111
Email: info@rawlplug.com
Web: www.rawlplug.com

SINGAPORE

Rawlplug Singapore Pte. Ltd.
Blk 302, #04-11, 25B Loyang Crescent
Loyang Offshore Supply Base
Singapore 506817
Tel: + 65 9078 5220
Email: jacek.nowicki@rawlplug.com.sg
Web: www.rawlplug.com

THAILAND

**Rawlplug Manufacturing
(Thailand) Limited**
Address: 888/43 Moo 9
T.Bangpla, A.Bangplee
Samutprakarn 10540
Thailand
Tel: +662 731 4788
Web: www.rawlplug.com

UNITED KINGDOM

Rawlplug Ltd
Skibo Drive
Thornliebank Industrial Estate
Glasgow G46 8JR
Tel: + 44 (0) 141 638 7961
Fax: + 44 (0) 141 638 7397
Email: rawlinfo@rawlplug.co.uk
Web: www.rawlplug.co.uk

FRANCE

Rawlplug France
Le Vinci - Hall 5
1-10 rue Henri Becquerel
77290 Mitry-Mory
Tel: + 33 (0) 1 6021 5020
Email: rawl@rawlplug.com
Web: www.rawlplug.fr

IRELAND

Rawlplug Ireland Ltd
Unit: 10 Donore Business Park
Donore Road Drogheda
Co Louth A92 C522
Tel: + 353 (0) 41 9844 338
Email: sales@rawlplug.ie
Web: www.rawlplug.ie

PORTUGAL

Rawlplug Lda
Business Park Maia
Rua Eng Frederico Ulrich 3110, B1
4470-605 Maia, Portugal
Email: pt.clientes@rawlplug.com
Tel. +351 221 174 633
Web: www.rawlplug.pt

SLOVAKIA

Rawlplug Slovakia s. r. o.
Jánošíkova 1
010 01 Žilina
tel.: +421 948 704 902
Email: objednavky.sk@rawlplug.com
Web: www.rawlplug.sk

TURKEY

**Rawlplug Turkey
Insaat Malzemeleri LTD. STI.**
FSM Mah. Poligon Cad. Buyaka 2
Sitesi 3 Blok No:8 C/1
Umraniye / Istanbul
Tel.: +90 (549) 139 59 57
Email: tr@rawlplug.com
Web: www.rawlplug.com

UNITED STATES OF AMERICA

Rawlplug Inc.
159 N Sangamon St., Ste 200 & 300
Chicago, IL 60607
Tel.: +1 312 940 5102
Web: www.rawlplug.us

CENTRAL TOOL SERVICE

phone: +48 (71) 320 92 18

serwis@rawlplug.com

CUSTOMER SERVICE

phone: +48 (71) 32 60 100

bok@rawlplug.com

www.modeco-expert.com



© RAWLPLUG®, 01.2024
INDEX: RM-CAT-MODEXP-ENG